

User Manual

AC Servo Spindle System

V1006-0015

(2.4)

Shenzhen Guanhong Automation CO.,LTD

Website: www.szghauto.com

Add:Room 503 Anxin Building, No 536 Shenhui Road, Liuyue community, Henggang
Street ,Longgang District, Shenzhen City,Guangdong Province, China

Post code: 518115

catalog

Chapter 1	Product Feature.....	1
1.1	Technical Specifications of Product.....	1
Chapter 2	Introduction of Spindle Servo Driver.....	2
2.1	Model Description of Spindle Servo Driver.....	2
2.2	Series.....	2
2.3	Expansion.....	2
Chapter 3	Wiring Description.....	3
3.1	Interface of Spindle Servo Driver.....	3
3.2	Standard wiring diagram.....	4
3.3	Functions of Main Circuit Terminal.....	5
3.4	Functions of Control Circuit Terminals(X5).....	5
3.4.1	Function description of X5.....	5
3.4.2	Digital Input Type Instruction.....	6
3.4.3	Digital Output Type Instruction.....	7
3.4.4	External Input Pulse Type Instruction.....	8
3.5	Expansion Interface---X6.....	9
Chapter 4	Instructions of Operation.....	10
4.1	Instructions of operation panel.....	10
4.2	Description of Keys on Operation Panel.....	10
4.3	Parameter Display.....	11
4.4	Operational Process.....	11
4.4.1	Description of Operation Panel control and Monitoring Parameter.....	12
4.4.2	Description of Operation Panel control.....	12
4.4.3	Description of Password (P A S)	12
4.5	Commissioning(Dry)	13
4.5.1	Wiring.....	13
4.5.2	Selfcheck For Phase.....	13
4.5.3	Control by Panel Operation.....	13
Chapter 5	Functional Specification.....	14
5.1	Motor Parameter.....	14
5.2	IO Specification.....	15
5.2.1	Monitor Parameter.....	15
5.2.2	DI Input Parameter.....	15
5.2.3	DO Output Parameter.....	15
5.3	Analog Voltage Modify.....	16
5.3.1	Parameter Set.....	16
5.3.2	Zero-Speed Modify.....	17
5.3.3	Analog-Voltage Segment Modify.....	17
5.4	Speed Control Mode.....	18
5.4.1	Speed Instruction.....	18
5.4.2	Monitoring Parameter.....	18
5.4.3	Performance Parameter.....	18

5.4.4 Acceleration & Deceleration.....	19
5.4.5 Direction of Speed Control Mode.....	19
5.4.6 Example: Speed Control Mode.....	20
5.5 Position Control Mode.....	24
5.5.1 Command Source.....	24
5.5.2 Monitored Parameter.....	24
5.5.3 Performance Parameter.....	24
5.5.4 Example.....	25
5.6 Homing Mode.....	27
5.6.1 Homing Mode.....	27
5.6.2 Monitored Parameter.....	27
5.6.3 Performance Parameter.....	27
5.6.4 Origin Signal(Z Pulse) Parameter.....	27
5.6.5 Trigger of Homing.....	27
5.6.6 Homing Movement Parameter.....	28
5.6.7 Example.....	29
5.7 Torque Control.....	32
5.7.1 Instruction source.....	32
5.7.2 Monitoring parameter.....	32
5.7.3 Performance Parameter.....	32
5.7.4 Torque Direction.....	33
5.7.5 Torque Acceleration/Deceleration.....	33
5.7.6 Torque Anti-overspeed.....	33
5.7.7 Example.....	34
5.8 Swing/JOG.....	36
5.9 Switching Control of Two-speed motor.....	36
5.9.1 Motor Wiring Diagram.....	38
5.9.2 Switching Status Table.....	39
Chapter 6 Parameter.....	40
6.1 Parameter Summary.....	40
6.1.1 Monitored Parameter.....	40
6.1.2 System Parameter (P series).....	41
Chapter 7 Safety Precautions.....	59
7.1 Failure and Solutions.....	59
7.2 Analysis on Common Malfunction.....	61
7.2.1 No indication after the driver has been connected to the power.....	61
7.2.2 Leakage protection switch trips.....	61
7.2.3 Symptom for encoder failure.....	61
7.2.4 Frequent Alarms of Er -01.....	62
7.2.5 Spindle can not be turned or rotate slowly without control.....	62
7.2.6 The spindle speed is inaccurately.....	63
7.2.7 Inaccurate positioning of spindle.....	63
Chapter 8 Spindle Servo Motor.....	66
8.1 Introduction of Spindle Servo Motor.....	66

8.2 Model Description of Spindle Servo Motor.....	66
8.3 Series.....	66
8.4 Specification of Spindle Servo Motor.....	67
8.5 Using Tips.....	67
8.5.1 Installation.....	67
8.5.2 Wiring.....	68
8.5.3 Repair and Maintenance.....	68
8.6 Motor Model Size.....	69
8.7 Dimension.....	71

Chapter 1 Product Feature

High performance

Control function comprehensive: stable speed control, accurate position control, excellent torque control.

Safe & Reliable

Products comply with international standards, through the CE certification. Set up multiple protection circuit, the comprehensive protection of safety equipment.

1.1 Technical Specifications of Product

Input power	Rated voltage/frequency	Three-phase 380V/480V; 50Hz/60Hz
	Allowable voltage range	+10% , -15%
	allowable frequency fluctuation	±5%
Control features	Control mode	PWM Vector control
	Speed adjustment range	0.01 ~ 500Hz
	Speed stabilization precision	±0.1%
	Acceleration/deceleration time	0.05 ~ 3000Hz/s
	Torque control	200% Rated torque output; Torque precision ± 5%
	position control precision	±1 Pulse
	Braking mode	Powered braking
	overload capacity	twice overload
I/O	Digital input	5 point , NPN or PNP
	Digital output	3 point , NPN
	Relay output	1 , DC30V/1A or AC250V/1A
	Analog input	2 , A0 : ±10V ; A1 : 0 ~ +10V or 4 ~ 20mA
	External pulse input	1 , AB、 SIGN+PLUS or CW
	Motor encoder input	1 , Receive frequency range:0~1MHz
	Motor encoder output	1 , Output frequency range :0~1MHz
Protection function	Over voltage protection,Low voltage protection,Over current protection Module protection ,Motor encoder failure,Motor over temperature,Motor overload protection	
Environment	Operating site	The product shall be mounted vertically in the electric control cabinet with good ventilation.The product shall be installed in the environment free from direct sunlight, dust, corrosive gas, combustible gas, oil mist, steam and drip.
	Ambient temperature	-10°C ~ +45°C
	Humidity	5 ~ 90% , no condensing
	Altitude	0 ~ 2000m, derated above 1000m, the rated output current shall be decreased by 1% for every rise of 100m
	Vibration	3.5mm,2~9Hz; 10 m/s ² ,9~200Hz; 15 m/s ² ,200~500Hz

Chapter 3 Wiring Description

3.1 Interface of Spindle Servo Driver

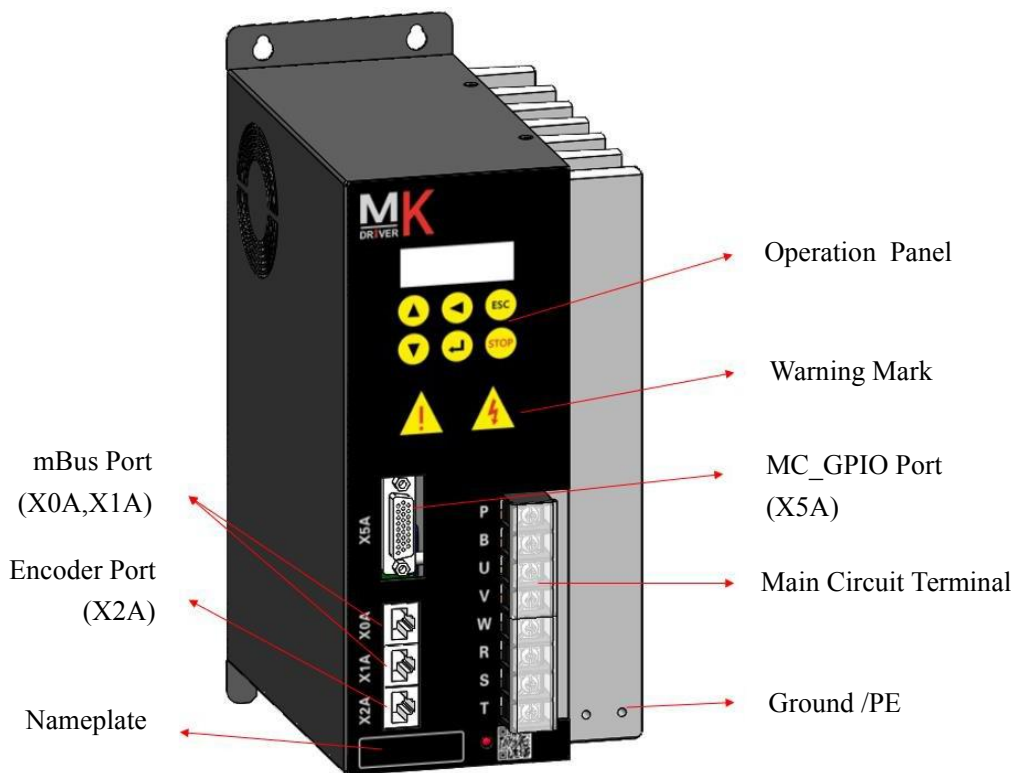

Fig3.1 Standard Type Spindle Servo Driver

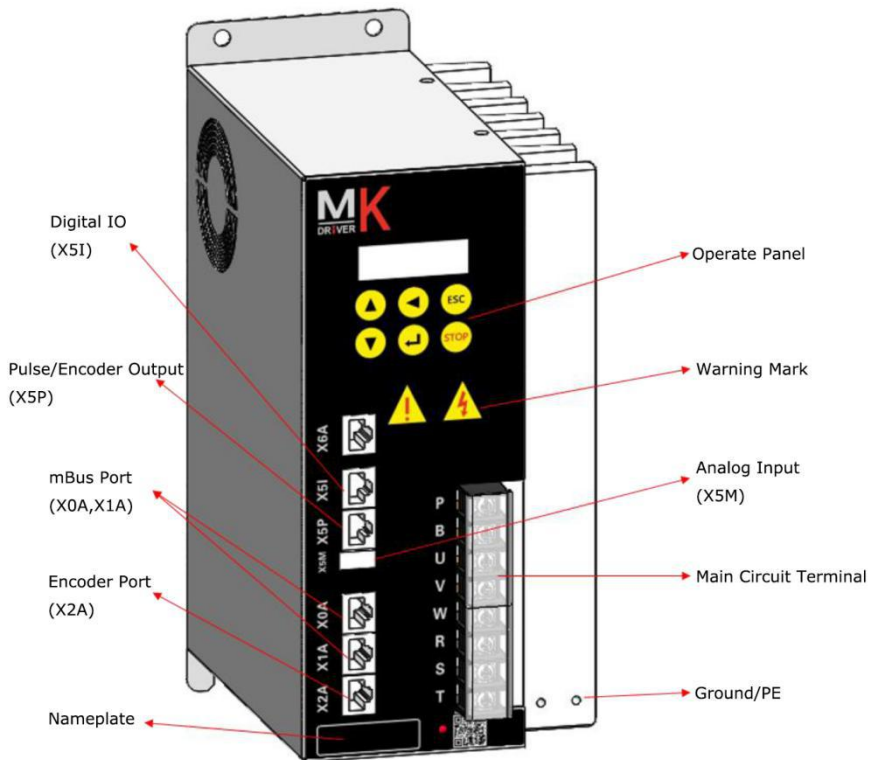
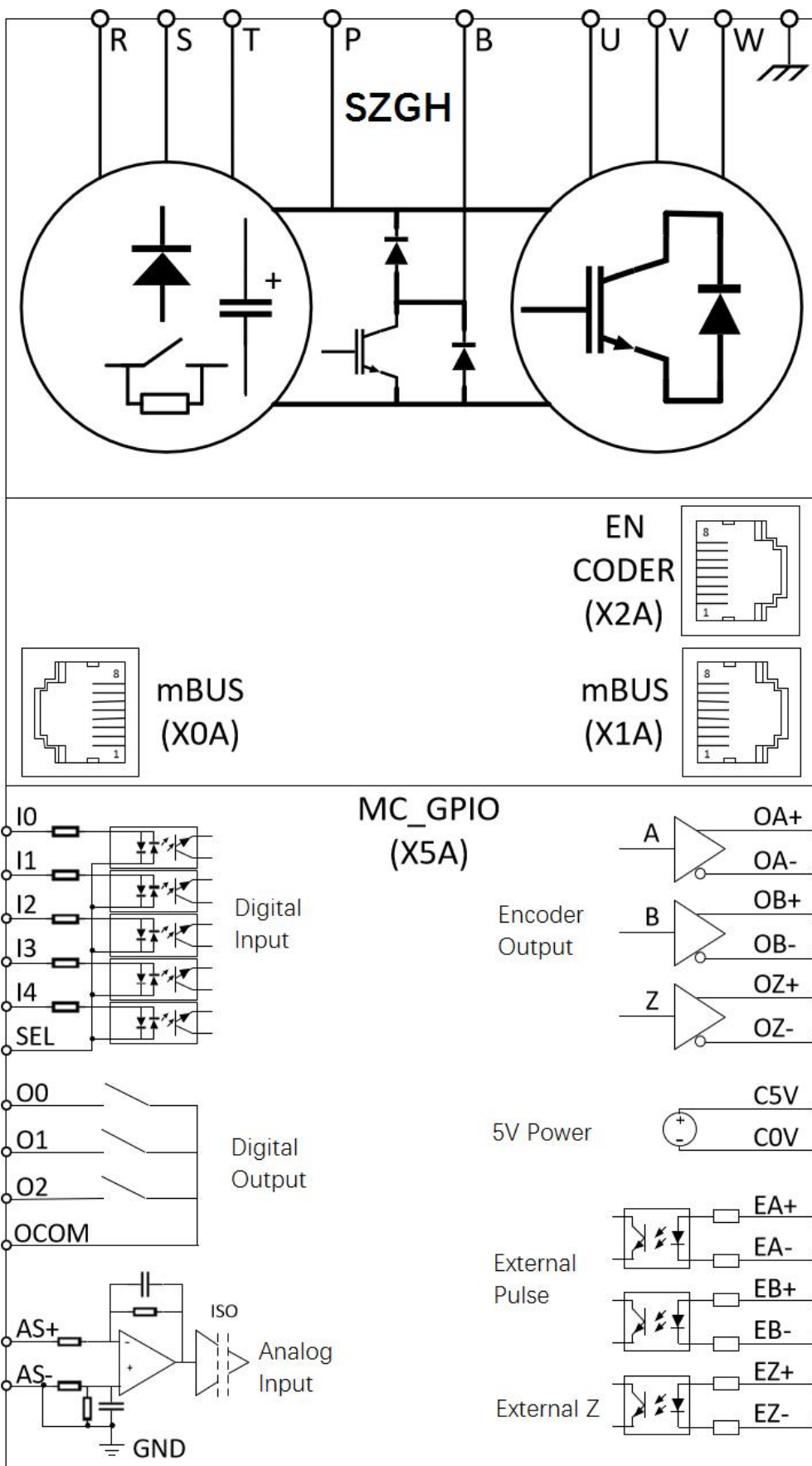



Fig3.2 GTIO-Port Spindle Servo Driver

3.2 Standard wiring diagram



3.3 Functions of Main Circuit Terminal

Terminal symbol	R , S , T	B1 , B2	U , V , W	
Function description	Three-phase AC input terminal	Connecting terminal of braking resistor	Three-phase AC output terminal	GND

Note: 1.Select right main circuit cable according to rated power of controller.

2.GND port must be connected to ground reliably,otherwise electric shock possible.

3.The main loop of the control loop cable please with separate cables and other power cable line, otherwise interfere with the control signal;

4.Don't connect input power to UVW port,which will damage controller.

3.4 Functions of Control Circuit Terminals(X5)

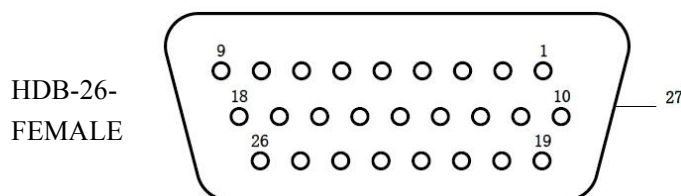

3.4.1 Function description of X5

	Digital input		Digital output		Analog input		External Pulse Input		Encoder Output	
	symbol	PIN	symbol	PIN	symbol	PIN	symbol	PIN	symbol	PIN
I/O	I0	10	O0	14	AS+	25	EA+/EP+/CW+	11	OA+	9
	I1	19	O1	5	AS-	26	EA-/EP-/CW-	2	OA-	18
	I2	1	O2	24			EB+/ED+/CCW+	13	OB+	17
	I3	20	OCOM	23			EB-/ED-/CCW-	4	OB-	8
	I4	21					EZ+	3	OZ+	7
	SEL	22					EZ-	12	OZ-	16
							C+5V	6		
							CGND	15		
Expl ain	5 Points, NPN/PNP selected by SEL		3 Group NO Output 24V/50mA		A0 : ±10V A1 : 0 ~ +10V or 0 ~ 20mA (Optional)		AB Pulse , Direction+Pulse , CW Pulse choice, Max response frequency is 500KHz		RS422 output,5V drive difference signal output	

1. 24V-COM need external power supply, 24 v for internal power supply please ordering

2. The digital quantity input type NPN (low level) effectively, PNP (effective) high level two, set way to see"digital input type Instruction"

3. SEL connection 24V, input type NPN, input low level

4. SEL connection 0V ,input type PNP , input high efficient

3.4.2 GTIO Port Define

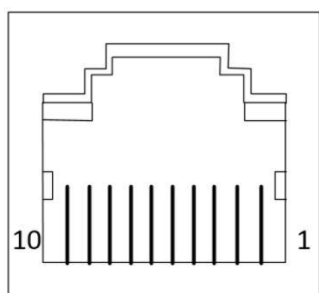

X5I Port

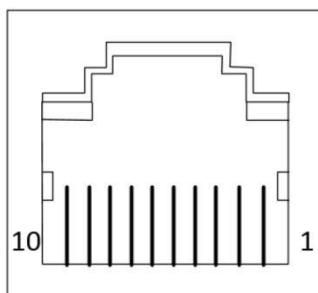

X5P Port

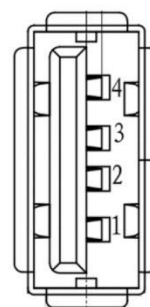

X5M Port

	Digital input		Digital output		Analog input	
	Symbol	PIN	symbol	PIN	Symbol	PIN
I/O	I0	X5I-6	O0	X5I-9	AS+	X5M-3
	I1	X5I-5	O1	X5I-8	AS-	X5M-2
	I2	X5I-4	O2	X5I-7	3.3V	X5M-1
	I3	X5I-3	OCOM	X5I-10	0V	X5M-4
	I4	X5I-2				
	SEL	X5I-1				
	Explain	5 Points, NPN/PNP selected by SEL		3 Group NO Output 24V/50mA		A0:±10V A1:0~+10V or 0~20mA (Optional)

IO	External Pulse Input		Encoder Output	
	Symbol	PIN	Symbol	PIN
	EA+/EP+/CW+	X5P-5	OA+	X5P-4
	EA-/EP-/CW-	X5P-6	OA-	X5P-7
	EB+/ED+/CCW+	X5P-1	OB+	X5P-8
	EB-/ED-/CCW-	X5P-10	OB-	X5P-9
			OZ+	X5P-2
			OZ-	X5P-3
	Explain	AB Pulse , Direction+Pulse , CW Pulse choice, Max response frequency is 500KHz		RS422 output,5V drive difference signal output

1. 24V-COM need external power supply, 24 v for internal power supply please ordering
2. The digital quantity input type NPN (low level) effectively, PNP (effective) high level two, set way to see"digital input type Instruction"
3. SEL connection 24V, input type NPN, input low level
4. SEL connection 0V ,input type PNP , input high efficient

3.4.3 Digital Input Type Instruction

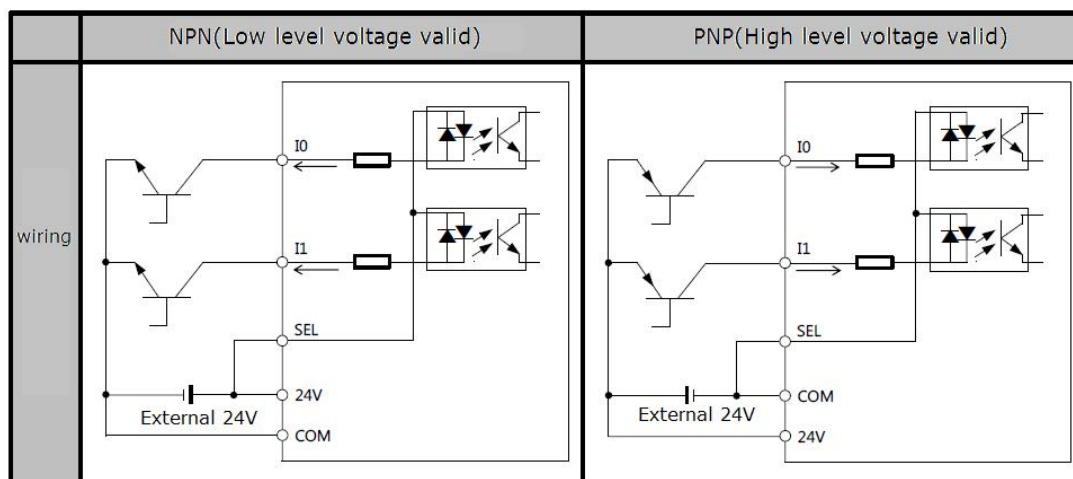

Note: 1.the digital input type is depend on SEL(Pin22)

- a) SEL connect 24V,input type is NPN,input low level voltage is valid;
- b)SEL connect 0V,input type is PNP,input high level voltage is valid;

3.4.4 Digital Output Type Instruction

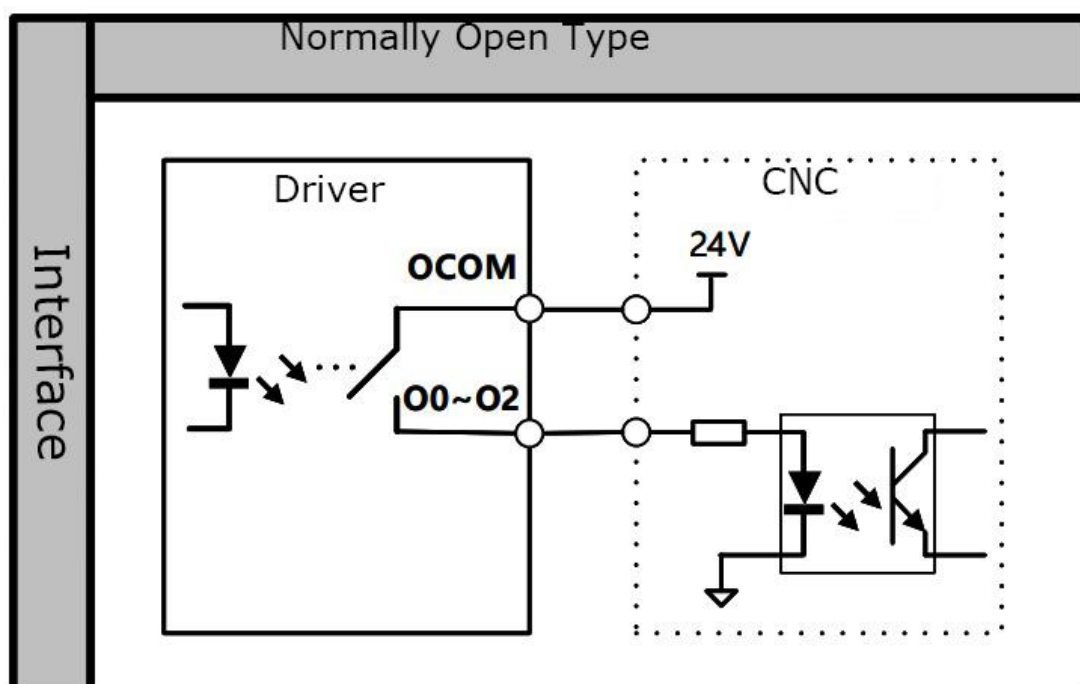

Note:

- 1.OCOM is connected to high level(Eg.: 24V), it outputs high level(Eg.:24V) when digital output is valid.
- 2.OCOM is connected to low level(Eg.: 0V), it outputs high level(Eg.:0V) when digital output is valid.

3.4.5 External Input Pulse Type Instruction

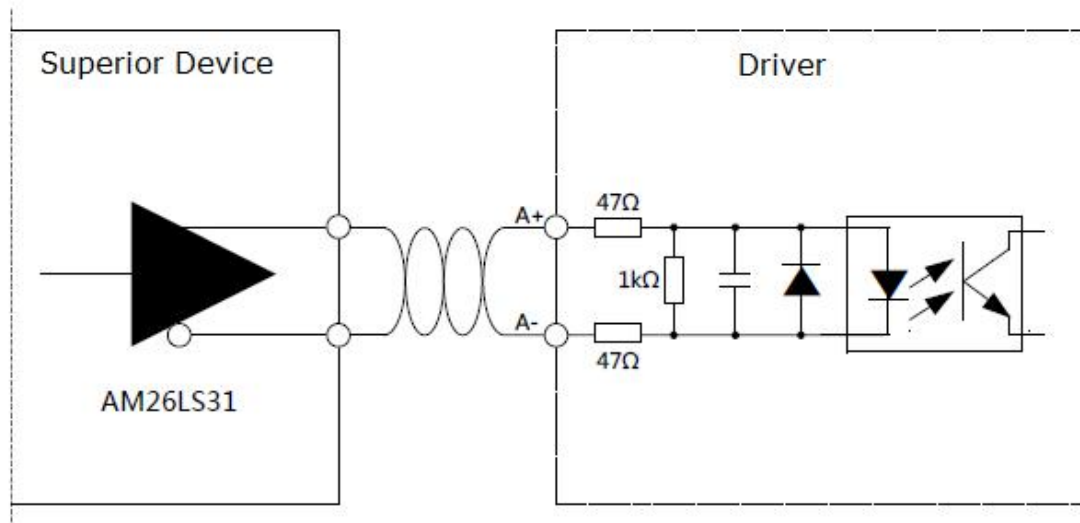

RS422 Differential signal drive

- Note: 1.the default set of driver is receiving 422 differential signal drive.
 2.this driving way most is used when connected with CNC system.

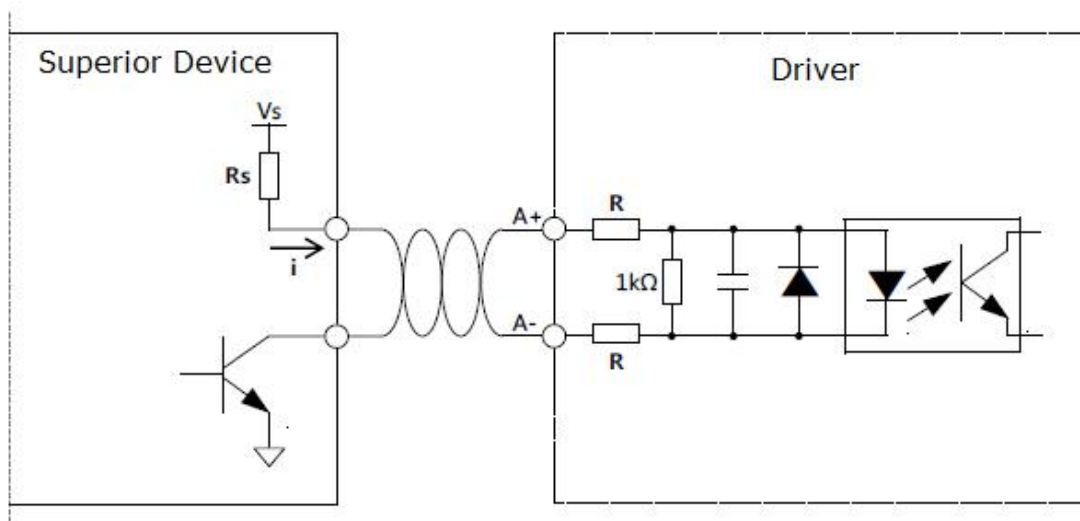

Open collector signal Driving

Note:

1.adopt this connect way,it need an external current limiting resistor R_s ,ensure i ,driving current, is about 10mA;driver's built-in current limiting resistor is 47Ω , V_s & R_s are set as follow:(make sure that driving current less than 18mA,otherwise it will broke down inner circuit.)

- a) $V_s=24V$, $R_s=2k\Omega$;
- b) $V_s=12V$, $R_s=1k\Omega$;
- c) $V_s=5V$, $R_s=200\Omega$.

2.when customer need this way,please tell the sales external voltage,the factory will alter the value of resistance,avoid add external resistance R_s ;

3.this driving way most is used when connected with PLC system.

3.5 Expansion Interface---X6

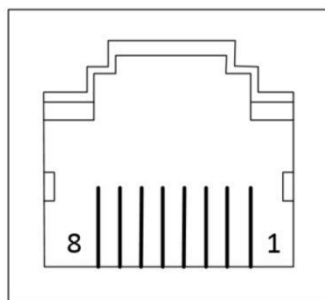

2nd Encoder Port

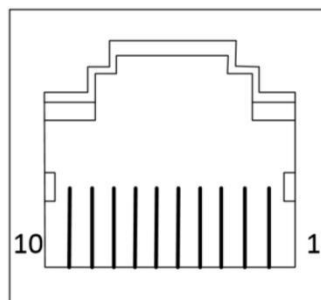

Expansion IO Port

The 2 nd encoder interface			Expansion IO interface		
PIN	Define name	Note	PIN	Define name	Note
1	Z3+	2 nd encoder Z+	1	SEL	Digital input command end
2	Z3-	2 nd encoder Z-	2	I8	The principle of digital input is same with the 3.4.3.1 shows
3	A3+	2 nd encoder A+	3	I9	
4	E5V	2 nd encoder power is 5V	4	I10	
5	EGND	2 nd encoder power is 0V	5	I11	
6	A3-	2 nd encoder A-	6	O10	The principle of digital input is same with the 3.4.3.2 shows
7	B3+	2 nd encoder B+	7	O9	
8	B3-	2 nd encoder B-	8	O8	
			9	O7	
			10	OCOM	Digital output command end
Receiving 422 differential signal drive					

Note:

1. X6A is expansion interface, it only can be used either 2nd encoder interface or expansion IO interface.

2. Installation will take place only when ordering be emphasized.

Chapter 4 Instructions of Operation

4.1 Instructions of operation panel

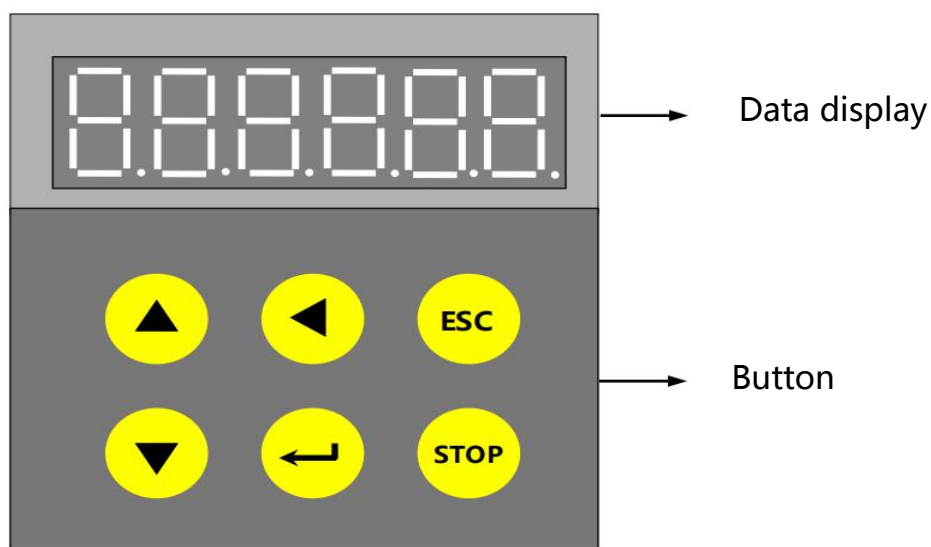

4.2 Description of Keys on Operation Panel

Symbol	Name	General Function	Multiplex Function
	Increase Key	Increasing the parameters value	None
	Decrease Key	Decreasing the parameters value	None
	Left Shift Key	Switching the data bit of parameters number	Switch between homologous series parameter set
	Enter Key	Finish the modification operation of parameters	Run the program at stop state
	Escape Key	Return to previous menu	Switching between different series of parameter set
	Stop Key	Making motor stop. Replace the driver fault	At run state,press shortly will stop speed,press continuously will stop program

Note:

1. Every one keys can be pressed repeatably.
2. Run on behalf of the servo system is in place, STOP on behalf of the servo system is not ready.

4.3 Parameter Display

- **Real-time parameter:** Word in left side is parameter number ;
Word in right side is parameter value.
- **Non-Real-time parameter:** 1st class is Parameter Number; display in left side;
2nd class is Current Parameter value; display in right side;
3rd class is Setting Parameter value; setting bit flicker;
- **Negative Number:** Dot before highest bit is on, which means negative number.

4.4 Operational Process

- Parameter Monitor & Panel Control Menu Shift:

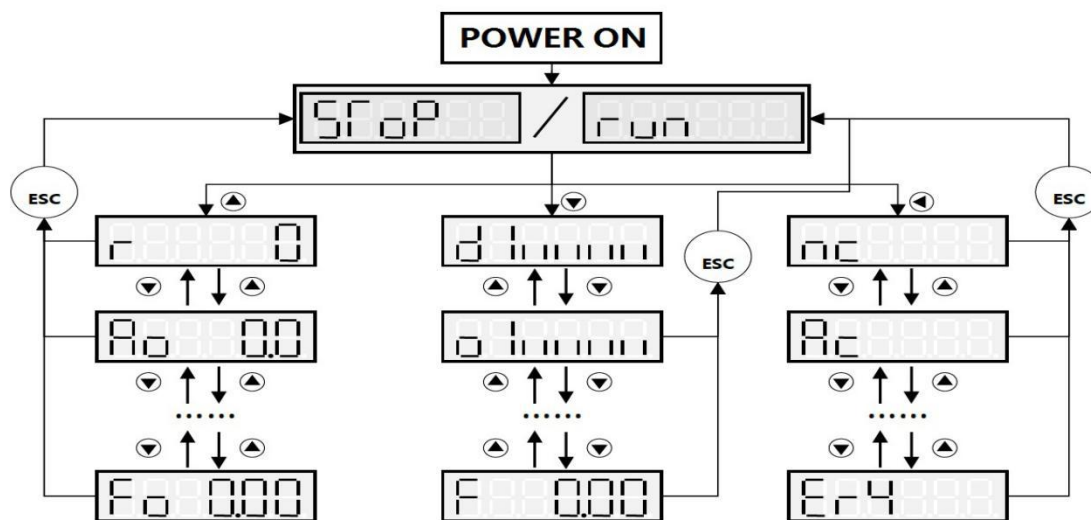

- Parameter Menu Shift

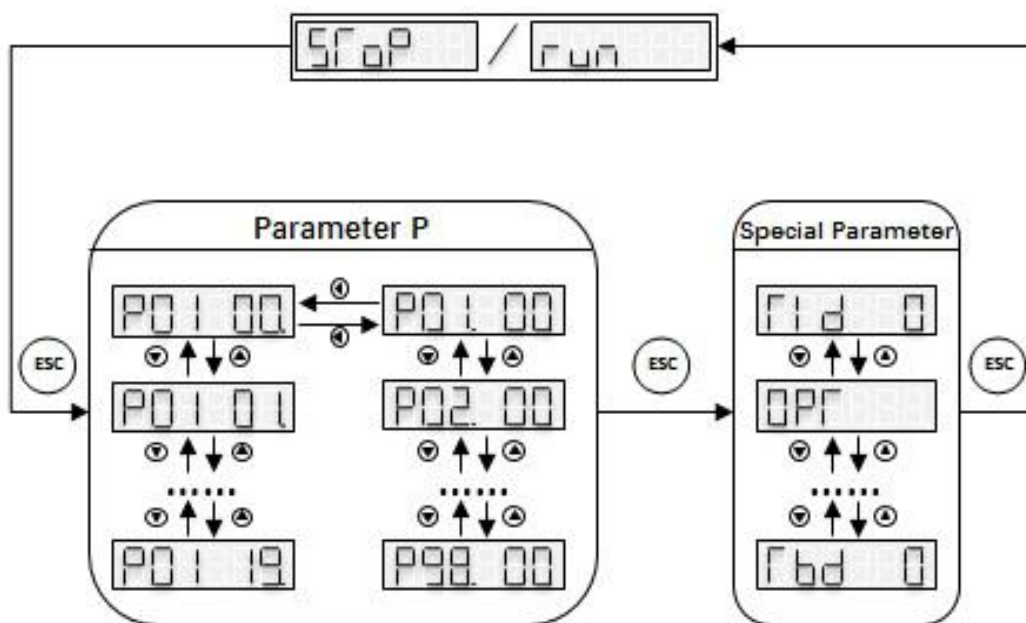







4.4.1 Description of Operation Panel control and Monitoring Parameter

Parameter number	Operation Panel control	Parameter number	I/O Monitoring	Parameter number	State Monitoring
nc	Setting speed of panel control	d	Digital input	Ao	Output current(A) (show 2.0 means 2.0 A)
ro	Running mode 0:continuous 1: JOG	o	Digital output		
Ac	Operational panel control,the acceleration 0~10000	A0	Analog inputA0	To	Output torque (100%)
		A1	Analog inputA1		
dc	The deceleration 0~10000	P	Motor encoder input	FI	Setting frequency (Hz)
F-E	Setting operation direction 0:forward 1: reverse	H	The absolute position of rotor		
OP	operation mode 0: I/O control 1:Operation Panel control 2:Dry	E	External pulse input	Fo	Output frequency (Hz)
Er	Press “Enter” to check of errors	F	Frequency of external pulse		

Note: ex-factory set dry(OP=2),after ensure the motor run normally,set OP=0.The detailed introduction,please check the Commission Parts.

4.4.2 Description of Operation Panel control

In displaying speed,press  key to set the motor' s speed nc ; press  key again,set the motor running model ro ; press  key again,set the motor' s direction F-E;press  key again,select OP as operational panel control mode.

After Setting Operation Panel control Parameter, Press  on the State Monitoring,the motor is on zero speed & be on power condition; Press **enter** key () at any monitoring condition ,The motor will run with set value. Press **STOP** Key will stop running when motor is running.after stopping,the motor is on the condition of zero speed & be on power ,press **STOP** key again,the motor is on the condition of Freedom & Off of power,Holding on **STOP** key,the program stop running(The run light will turn off.)

4.4.3 Description of Password (P A S)

To prevent the irrelevant personnel modify manufacturer parameters,Need password into the manufacturer of parameter, if there is a need to amend manufacturer parameters, please contact with our company

4.5 Commissioning(Dry)

4.5.1 Wiring

- Before power on, please check wiring.
 - 1) Power Lines (TAG: R, S, T), 3-phase 380VAC input
 - 2) Motor Lines (TAG: U, V, W), 3-phase output(U,V,W)
 - 3) Braking Resistor Lines (TAG: P , B)
 - 4) Motor Encoder Lines (TAG: X2A) connect to motor encoder terminal
 - 5) Check drive grounding are in good condition

4.5.2 Self-check For Phase

- 1) Check if the axis of motor can freely rotate(Non-enable shaft)
- 2) Check parameters, such as E00, E04;
- 3) When the panel display “run”,press “Left shift key” to “oP”,and set to 2, (oP=2, phase sequence learning mode) , motor phase start check;
- 4) Motor phase self-check will be finished in 5 seconds, if warning occur, please see the warning list in Chapter 8;
- 5) If an exception occurs in self-check(Such as over-current), then press “STOP” continuously to stop the driver.

4.5.3 Control by Panel Operation

- Control motor through manually typing drive panel (such as speed,direction,acceleration, etc.);
- When the control of CNC is abnormal, user can choose panel control to check if the wire between drive and motor is right and if the parameter is right.
 - 1) When panel display “run”, press “Left shift ”key twice to “oP”, set oP=1;
 - 2) Press “Left Shift ”key to “nc”, set the desired speed;
 - 3) Press “Left Shift” key to “ac”, set acceleration;
 - 4) Press “Left Shift” key to “dc”, set deceleration;
 - 5) Press “Left Shift” key to “FE”, set direction;
 - 6) Press “ESC” to return to “run” display, press “Increase” key one time to display “r00000”;
 - 7) Press “Enter”key one time to enable motor zero speed; Press “Enter” key again, motor will run according to setting speed.
 - 8) Press “STOP” key one time, motor decelerate to zero and lock shaft; Press “STOP” key again, disable motor.
 - 9) Press “STOP” key continuously, motor free sliding; at “STOP” state,press “ESC” key to return to “run” state.

Chapter 5 Functional Specification

5.1 Motor Parameter

Para No	Address	Parameter Name	Range	Default	Unit
P14_00	0x2260	Motor Encoder Type	0~100	1	-
P14_01	0x2262	Motor Single Turn Encoder Line Number	1~100000000	1024	-
P14_06	0x226C	Motor Encoder Speed Filter Time	1~50	3	ms
P01_01	0x2102	Motor Poles	Please follow the Motor nameplate		-
P01_02	0x2104	Motor Rated Frequency			Hz
P01_03	0x2106	Motor Maximum Frequency			Hz
P01_04	0x2108	Motor Rated Voltage			V
P01_05	0x210A	Motor Rated Current			A
P01_06	0x210C	Motor Rated Torque			Nm
P01_07	0x210E	Motor Rated Flux Current			=0.3x Motor Rated Current
P01_08	0x2110	Motor Flux Current Coff	0.01~1.5	0.2	-
P01_09	0x2112	Motor Flux weak Coff	0.01~1	0.1	-
P01_10	0x2114	Motor Moment of Inertia	0~99.9999	0.1	kgm ²
P01_11	0x2116	Motor Zero Speed Torque Multiple	0.1~4	2	-
P01_12	0x2118	Motor Rated Torque Multiple	0.1~4	2	-
P01_13	0x211A	Motor Constant Power Max Speed	=3~4 x Motor Rated Current		
P01_14	0x211C	Motor Zero Slip Compensate Coff	0~10	1	-
P01_15	0x211E	Motor Rated Slip Compensate Coff	0~10	1	-
P01_16	0x2120	Motor Max Slip Compensate Coff	0~30	6	-
P01_17	0x2122	Motor Zero Slip Compensate Coff Speed	=3x Motor Rated Speed		
P01_18	0x2124	Motor Pos Zero Slip Compensate Coff	0~10	1.5	-
P01_19	0x2126	Motor Pos Rated Slip Compensate Coff	0~10	2	-

Note: for dual speed spindle servo, P01 group parameters are for low speed gear, P02 group parameters are for high speed gear.

5.2 IO Specification

5.2.1 Monitor Parameter

Para. No.	mBUS Add.	Name	Explain
d1 ~ d8	0x2364	DI	Digital Input Monitor, FWD,REV,Orientation, Position,... (I0,I1,I2... from right to left)
o1 ~ o4	0x2380	DO	Digital Output Monitor, Alarm,Orientation End, C-Ready,Speed Reach, (O0,O1,O2... from right to left)

5.2.2 DI Input Parameter

Spindle servo driver total has 5 digital inputs, which are at X5 port. Each input can be defined to any function.

Para. No.	mBUS Add.	Name	Setting & Function
P23_10	0x236D	I0	0: Forward; 1:Reverse; 2:Orientation 0 3:Orientation 1 ;4:Position Control; 5:Emergency Stop; 6:Swing Control 7:Reset;8:JOG_CW; 9:JOG_CCW; 10:Torque Control; 11:3 Orientation 2; 12:Orientation3 13:Over-Heating; 14:Dual_Speed_Shift(high) 15:Dual_Speed_Shift(Low); 16:Dual_Speed_Shift(Remark) 17~20: 16Gears(x1, x2, x3, x4) 23~25:MPG Ratio(x1, x10, x50); 26:X1 Quasi-Stop; 27:X2 Quasi-Stop; 28:X3 Quasi-Stop 29:X4 Quasi-Stop; 127:Null
P23_11	0x236E	I1	
P23_12	0x2370	I2	
P23_13	0x2372	I3	
P23_14	0x2374	I4	

5.2.3 DO Output Parameter

Spindle servo driver total has 7 digital output, which are at X3,X4,X5 port. Each output can be defined to any function.

Para. No.	mBUS Add.	Name	Setting & Function
P24_10	0x23B8	O0	0: Alarm Output; 1: Orientation End; 2: C Ready 3:Speed Arrival; 4:Driver Ready; 5:Fan Output 6:Dual_Speed_Shift; 7:Braker; 8:Remain 9:Zero Speed arrival;10~13:Torque output 16 grade 0~3;14:Rapier machine is effective;15:Motor torque output alarm;16:Front limit switch is effective;17:Posterior limit switch is effective 127:Ineffective
P24_11	0x23BA	O1	
P24_12	0x23BC	O2	

Note: above number +128, output type is NC type. When driver power off, all outputs are off condition

5.3 Analog Voltage Modify

There would influences from external industrial environment during actual using with analog speed control mode, which will affect error of analog voltage between CNC system (upper unit) output & Input to servo driver & trouble. And function of analog voltage modify will solve the problem, and adjust input voltage to theoretical value.

5.3.1 Parameter Set

➤ Monitor Parameter

Para. No.	mBUS Add.	Name	Explain
A0	0x2316	Non-revised Analog Input	Unit: v
A1	0x2318	Revised Analog Input	Unit: v

Note: Press “Decrease” key to “A0” at “run” state.

➤ 0V~10V Modified Parameter

Para.No.	mBUS Add.	Name	Explain
P21_10	0x231A	Zero Range in Positive	Default: 0v: A0 value
P21_12	0x231E	Voltage of 1st class in Positive	Default: +2v: A0 value
P21_14	0x2322	Voltage of 2nd class in Positive	Default: +4v: A0 value
P21_16	0x2326	Voltage of 3rd class in Positive	Default: +6v: A0 value
P21_18	0x232A	Voltage of 4th class in Positive	Default: +8v: A0 value
P21_19	0x232C	Voltage of 10v in Positive	Default: +10v: A0 value

➤ -10V~0V Modified Parameter

Para.No.	mBUS Add.	Name	Explain
P21_20	0x232E	Zero Range in Negative	Default: 0v: A0 value
P21_22	0x2332	Voltage of 1st class in Negative	Default: +2v: A0 value
P21_24	0x2336	Voltage of 2nd class in Negative	Default: +4v: A0 value
P21_26	0x233A	Voltage of 3rd class in Negative	Default: +6v: A0 value
P21_28	0x233E	Voltage of 4th class in Negative	Default: +8v: A0 value
P21_29	0x2340	Voltage of 10v in Negative	Default: +10v: A0 value

➤ Filter Parameter of Analog Voltage

Para.No.	mBUS Add.	Name	Explain
P21_00	0x2310	Filter time constant of analog voltage	Adopting filter time of analog

5.3.2 Zero-Speed Modify

- 1) Use SZGH CNC Controller to run “M03 S0”(Zero speed code) on MDI, and check A0 on spindle servo driver
- 2) Input value of A0 to P21_10(little more than A0)
- 3) Input value of A0 to P21_20(little less than A0)

5.3.3 Analog-Voltage Segment Modify

Divide 0V~10V analog voltage to 5 segments to modify, segment points are P21_11, P21_13, P21_15, P21_17, ;

Divide -10V~0V analog voltage to 5 segments to modify, segment points are P21_21, P21_23, P21_25, P21_27,

Example:

- 1) In this case, -10V ~ +10V corresponding motor speed range is -6000rpm ~ 6000rpm;
- 2) Firstly modify 0~10V analog voltage;
- 3) Set P55_05=6000,P21_11=2.000,P21_13=4.000, P21_15=6.000, P21_17=8.000;
- 4) CNC run: M03 S1200, input current value of A0 to P21_12,
- 5) CNC run: M03 S2400, input current value of A0 to P21_14,
- 6) CNC run: M03 S3600, input current value of A0 to P21_16,
- 7) CNC run: M03 S4800, input current value of A0 to P21_18,
- 8) CNC run: M03 S6000, input current value of A0 to P21_19,
- 9) Secondly modify -10V~0V analog voltage;
- 10) Set P21_21=.2.000, P21_23=.4.000, P21_25=.6.000, P21_27=.8.000;
- 11) CNC run: M04 S1200, input current value of A0 to P21_22,
- 12) CNC run: M04 S2400, input current value of A0 to P21_24,
- 13) CNC run: M04 S3600, input current value of A0 to P21_26,
- 14) CNC run: M04 S4800, input current value of A0 to P21_28,
- 15) CNC run: M04 S6000, input current value of A0 to P21_29,
- 16) Now, check A1 monitoring parameter, to confirm the modify result.

5.4 Speed Control Mode

Speed control mode is applied to precise speed control occasions, such as braiding machine, CNC machine, and position control also can be realized through CNC.

5.4.1 Speed Instruction

There are several different sources of speed instruction in Speed control mode, which is set by P55_02 parameter.

Para. No.	Description	Explanation
0	Analog Speed code: 0~10V	Input Port: AS+/AS-
1	Analog speed code: ±10V	Input Port: AS+/AS-
2	Pulse Speed code: External Pulse	Input Port: AS+/AS-
3	Bus Speed Code : mBUS	mBUS set speed
4	IO Combined Speed : 16 Gear Speed	IO

5.4.2 Monitoring Parameter

Para. No.	mBUS add.	Para. Name	Description
d	0x2364	Digital Input	Digital Input Monitor
A1	0x2318	Corrected Analog Input	Unit: V
F	0x2358	External Pulse Frequency	Unit: Hz
FI	0x2408	Motor Command Frequency	Unit: 0.01Hz
Fo	0x240A	Motor Output Frequency	Unit: 0.01Hz
Ao	0x2228	Motor Output Current	0.1A
To	0x2238	Motor Output Torque	%
r	0x2276	Motor Speed	Unit: rpm

5.4.3 Performance Parameter

Para. No.	mBUS Add.	Para. Name	Set Value	Unit	Parameter No
ASR Parameter					
P34_00	0x2500	ASR KP high speed	0~2	0.18	-
P34_01	0x2502	ASR KP low speed	0~2	0.2	-
P34_02	0x2504	ASR Inertia Con	0~2	0.32	-
P34_03	0x2506	ASR KI Low stable speed	0~0.5	0.01	-
P34_04	0x2508	ASR KI High stable speed	0~0.5	0.004	-
P34_05	0x250A	ASR KI Acceleration & Deceleration at low speed	0~0.5	0.005	-
P34_06	0x250C	ASR KI Acceleration & Deceleration at high speed	0~0.5	0.002	-

5.4.4 Acceleration & Deceleration

Para. No.	mBUS Add.	Para. Name	Set Value	Unit
P55_07	0x298E	Acceleration at Low Speed (Speed Control)	20	Hz/s
P55_08	0x2990	Deceleration at Low Speed (Speed Control)	20	Hz/s
P55_09	0x2992	Acceleration Transformation Point	3000	rpm
P55_10	0x2994	Acceleration at High Speed (Speed Control)	20	Hz/s
P55_11	0x2996	Deceleration at High Speed (Speed Control)	20	Hz/s
P52_02	0x2844	Emergency Stop Deceleration	50	Hz/s

At speed control mode, motor speed is controlled as the setting acceleration and deceleration. As shown in the figure below, F02 sets the acceleration curve of motor at low speed, F03 sets the deceleration curve of motor at low speed, F05 sets the acceleration curve of motor at high speed, F06 sets the deceleration curve of motor at high speed, F04 sets the acceleration transformation point of motor.

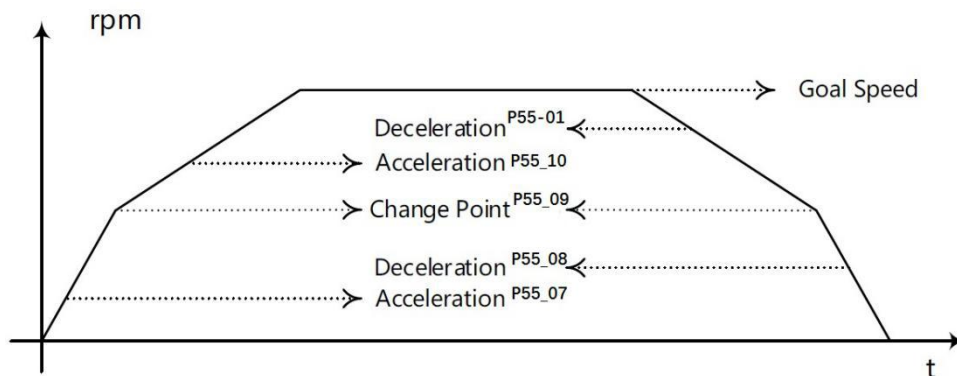

- Formula of Acceleration and Deceleration Parameter (P55_07, P55_08, P55_10, P55_11, P52_02) and Time:

$$P_x = \frac{1}{30} * \frac{|r_1 - r_2|}{t}$$

r1 is current speed(rpm), r2 is target speed(rpm), t is acceleration time or deceleration time(s).

- Example: Time of motor speed from 0 to 3000rpm is 1s.
- ✓ If P55_09>3000(use acceleration at low speed), P55_07=(3000-0)/30*1=100;
- ✓ If P55_09=1500(acceleration is different at low & high speed):
 Acceleration time at low speed is 0.4s, P55_07=(1500-0)/30*0.4=125;
 Acceleration time at high speed is 0.6s. P55_10=(3000-1500)/30*0.6=83.33;

5.4.5 Direction of Speed Control Mode

Seq. No.	P55_14	P55_15	Description
1	0	0	r=r
2	1	0	r= -r
3	x	1	If r<0 , r=0

5.4.6 Example: Speed Control Mode

5.4.6.1 Instruction Type: 0~10V Analog Voltage

➤ The wiring diagram:

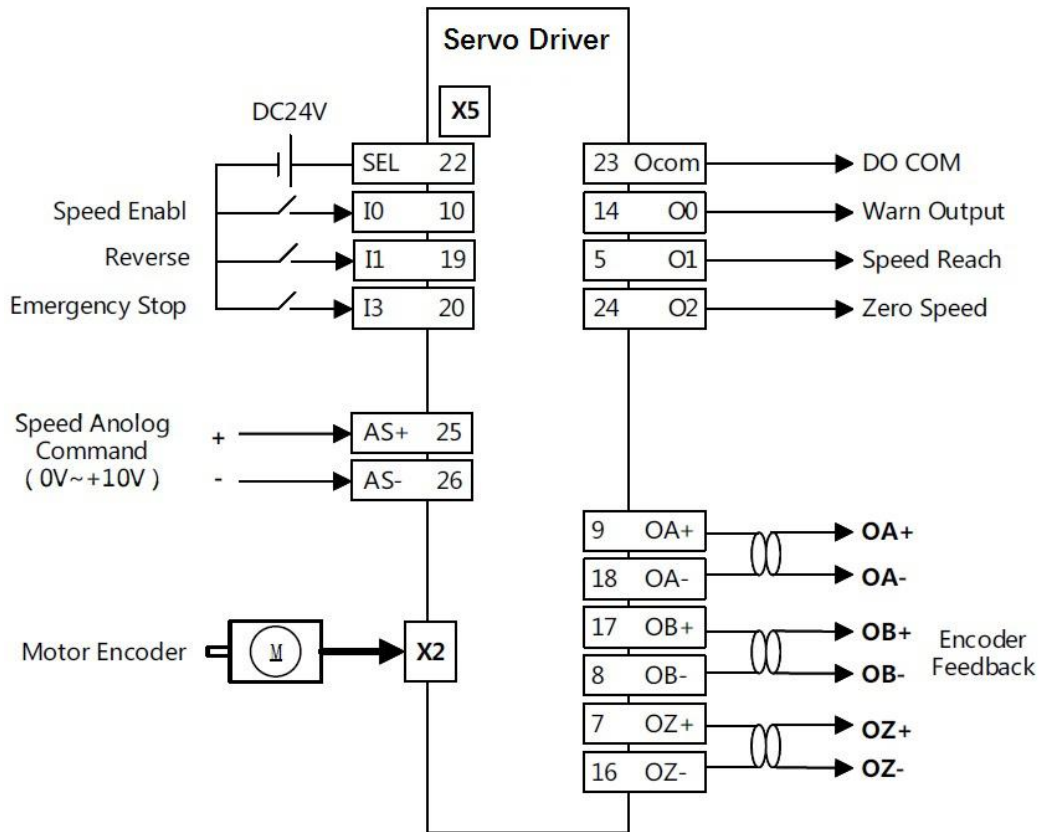

➤ **Parameter Set:**

Para. No.	mBUS Add.	Para. Name	Set Value
P23_10	0x236C	I0 Definition	0
P23_11	0x236E	I1 Definition	1
P23_13	0x2372	I3 Definition	5
P24_10	0x23B8	O0 Output Definitions	0
P24_11	0x23BA	O1 Output Definitions	3
P24_12	0x23BC	O2 Output Definitions	9
P55_02	0x2984	Speed Command Type	0

➤ **Parameter about speed instruction and analog voltage:**

Para. No.	mBUS Add.	Para. Name	Set Value
P21_04	0x2318	Corrected Analog Input Value	
P55_18	0x29A4	Speed Instruction Resolution	1
P55_05	0x298A	Max Speed(Speed Control)	3000
P55_06	0x298C	Min Speed(Speed Control)	0
P55_13	0x299A	Speed Command Gear Ratio Numerator	1

➤ **Speed Command Formula:** (P55_06 ≤ |r| ≤ P55_05)

$$r = \frac{AI}{10.000} * P55_05 * P55_13$$

5.4.6.2 Instruction Type: Orthogonal External Pulse

➤ **The wiring diagram:**

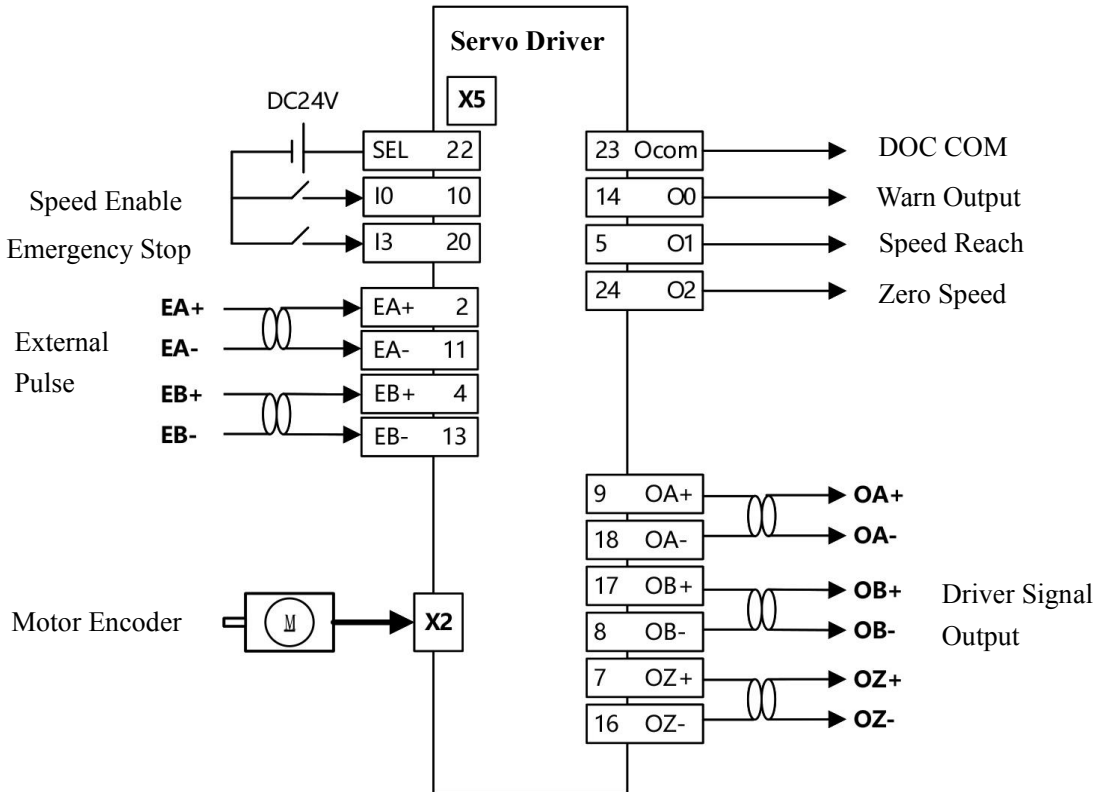

➤ **Parameter Set:**

Para. No.	mBUS Add.	Para. Name	Set Value
P23_10	0x236C	I0 Definition	0
P23_13	0x2372	I3 Definition	5
P24_10	0x23B8	O0 Output Definitions	0
P24_11	0x23BA	O1 Output Definitions	3
P24_12	0x23BC	O2 Output Definitions	9
P55_02	0x2984	Speed Command Type	0

➤ **The Relevant Parameter of Speed Instruction and External Pulse:**

Para.No.	Mbus Add.	Para.Name	Value
P22_00	0x2350	Pulse Frequency Filtering Time constant	5
P22_01	0x2352	Type of External Pulse	0

➤ **The Relevant Parameter of Speed Instruction:**

Para.No.	mBUS Add.	Para. Name	Value
F	0x2358	Frequency of External Pulse	
P55_05	0x298A	Highest Speed(Speed control)	5000
P55_06	0x298C	Lowest Speed(Speed control)	0
P55_13	0x299A	Speed Instruction Gear Rate	1

➤ **Speed Command Formulas:(P55_06 ≤ |r| ≤ P55_05)**

$$R = 30 * F * P55_13$$

5.4.6.3 Instruction Type: mBUS

The wiring diagram:

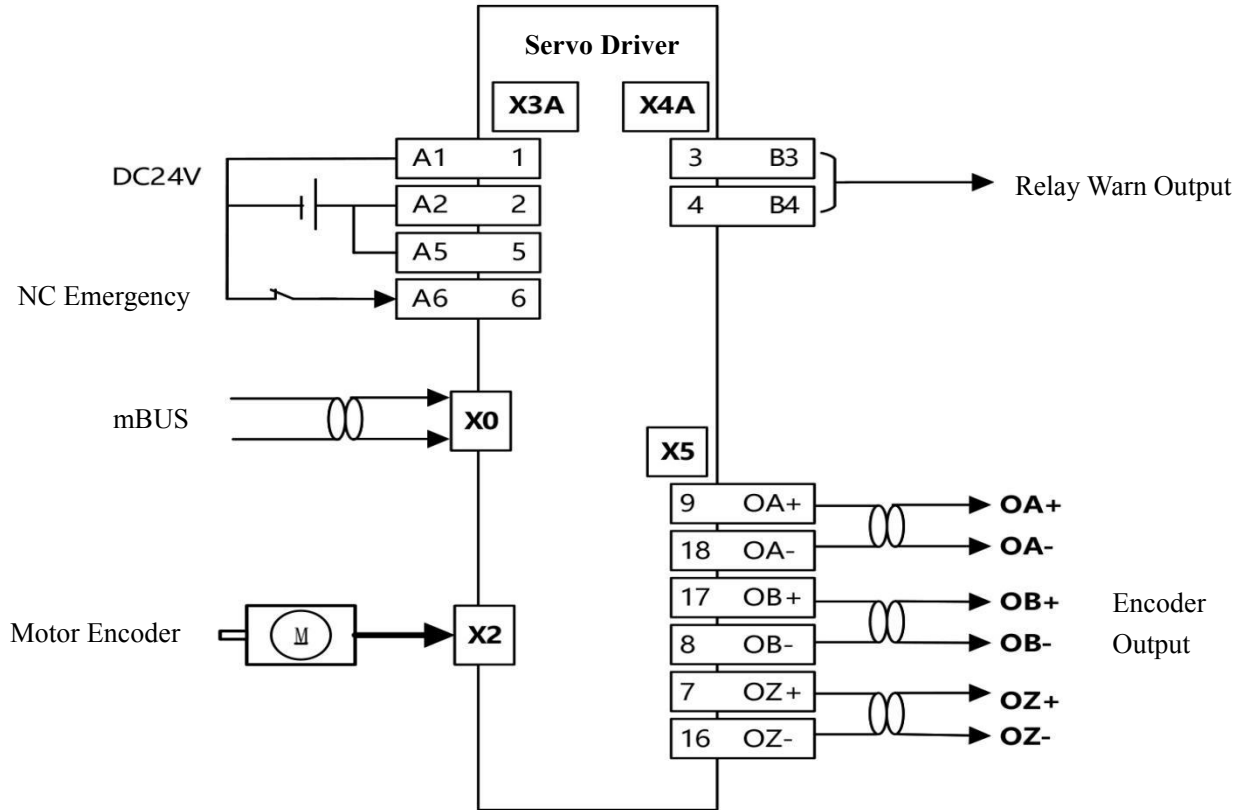

➤ **Parameter Set**

Para. No.	mBUS Add.	Para. Name	Set Value
P23_16	0x2378	I6 Input Definition	5
P24_14	0x23C0	O4 Output Definition	0
P55_02	0x2983	Chose for type of Speed Instruction	3

➤ **Parameter of mBUS and Speed Instruction:**

Para. No.	mBUS Add.	Para. Name	Set Value
P23_30	0x238C	mBUS digital Input	5
P24_14	0x29A6	mBUS Speed Instruction	Adaption

➤ **Parameter of Speed Instruction:**

Para. No.	mBUS Add.	Para. Name	Set Value
P55_05	0x298A	Highest Rotation Speed	3000
P55_06	0x298C	Lowest Rotation Speed	0
P55_13	0x299A	Speed Instruction Rate	1

➤ **Speed calculation Command formula : (P55_06 ≤ |r| ≤ P55_05)**

$$r = P55_19 * P55_13$$

5.4.6.4 Instruction Type: IO combination when at 16 Gears

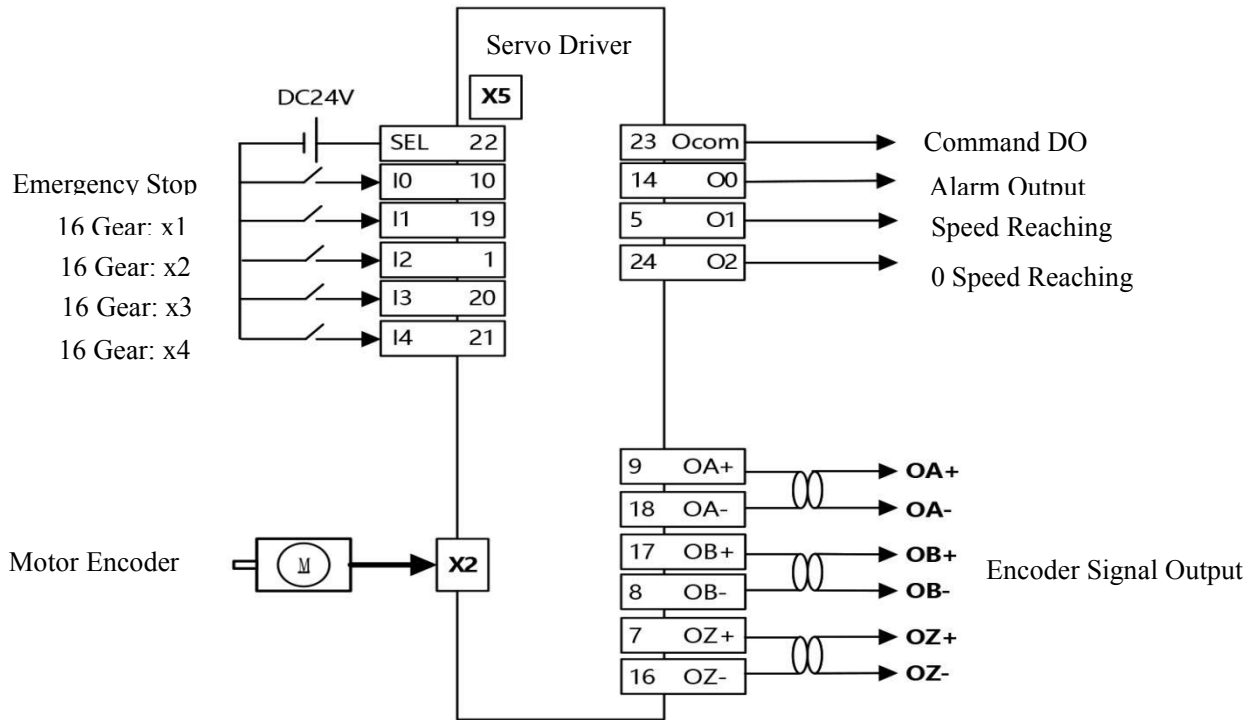

➤ **Parameter Setting**

Para. No.	mBus Add.	Para.Name	Para.Set	Description
P23_10	0x236C	I0 Input definition	5	Speed Enable
P23_11	0x236E	I1 Input definition	17	16 Gear: x1
P23_12	0x2370	I2 Input definition	18	16 Gear:x2
P23_13	0x2372	I3 Input definition	19	16 Gear: x3
P23_14	0x2374	I4 Input definition	20	16 Gear: x4
P24_10	0x23B8	O0 Output definition	0	Alarm Output
P24_11	0x23BA	O1 Output definition	3	Speed Reaching
P24_12	0x23BC	O2 Output definition	9	0 Speed Reaching
P55_02	0x2984	Speed Instruction Input and chose type	4	IO Combination when at 16 Gears

➤ **Parameter Setting when at 16 Gears**

Para. No.	mBus Add.	Para.Name	Parameter Setting	Description
P55_20	0x29A8	0 Speed Gear	Adaption	Positive and negative speed can be set Unit: rpm
P55_21	0x29AA	1st Speed Gear	Adaption	
...	
P55_35	0x29C6	15th Speed Gear	Adaption	

➤ **Parameter about Speed Instruction**

Para. No.	mBus Add.	Para.Name	Para. Set	Description
P55_05	0x298A	The highest RPM(Speed control)	3000	
P55_13	0x299A	Speed Instruction Gear Ratio	1	

5.5 Position Control Mode

Position Control Mode is applied to precision positioning systems, such as CNC machine tools, robots, etc. Position command source includes pulse command, analog command, mBUS.

5.5.1 Command Source

P53_02	Description	Explanation
0	Analog Voltage: 0~10V	10V Corresponding Max Speed
1	Analog Voltage: ±10V	±10V Corresponding Max Speed
2	External Pulse	AB Pulse, PD Pulse, CCW Pulse
3	mBUS(Absolute)	Pulse Interpolation Count
4	mBUS(Incremental)	Unit Time Pulse Increasing Number

5.5.2 Monitored Parameter

Para. No.	mBus Add.	Para.Name	Description
d	0x2364	Digital Input	Digital Input Monitor
P	0x2272	Motor Encoder Count	Unit: pulse
E	0x2356	External Pulse Count	Unit: pulse
C	0x240C	Position Command Pulse	Unit: pulse
U	0x2410	Synchro Error	Unit: pulse
Ao	0x2228	Motor Output Current	Unit: A
To	0x2238	Motor Output Torque	Unit: Rated Torque Multiple
r	0x2276	Motor Speed	Unit: rpm

5.5.3 Performance Parameter

Para. No.	mBUS Add.	Para.Name	Range	Default	Unit
P35_00	0x2594	APR Inertia coefficient	0~2	0.5	-
P35_02	0x2596	APR KI zero speed	0~1	0.1	-
P35_03	0x2598	APR KI low speed	0~1	0.1	-
P35_04	0x259A	APR KI high speed	0~1	0.05	-
P35_05	0x259C	APR KP zero speed	0~2	0.5	-
P35_06	0x259E	APR KP low speed	0~2	0.2	-
P35_07	0x25A0	APR KP high speed	0~2	0.1	-
P53_07	0x288E	Position control position rigidity	0.00001 ~1	0.001	-
P53_08	0x2890	Position control acceleration rigidity	0~1	0.001	-
P53_09	0x28B0	Position control inertia rigidity	0.00001 ~1	0.001	-

* Position Control Mode: 0:Synchronous Mode; 1:Following Mode.

5.5.4 Example

5.5.4.1 Instruction Type: Orthogonal External Pulse

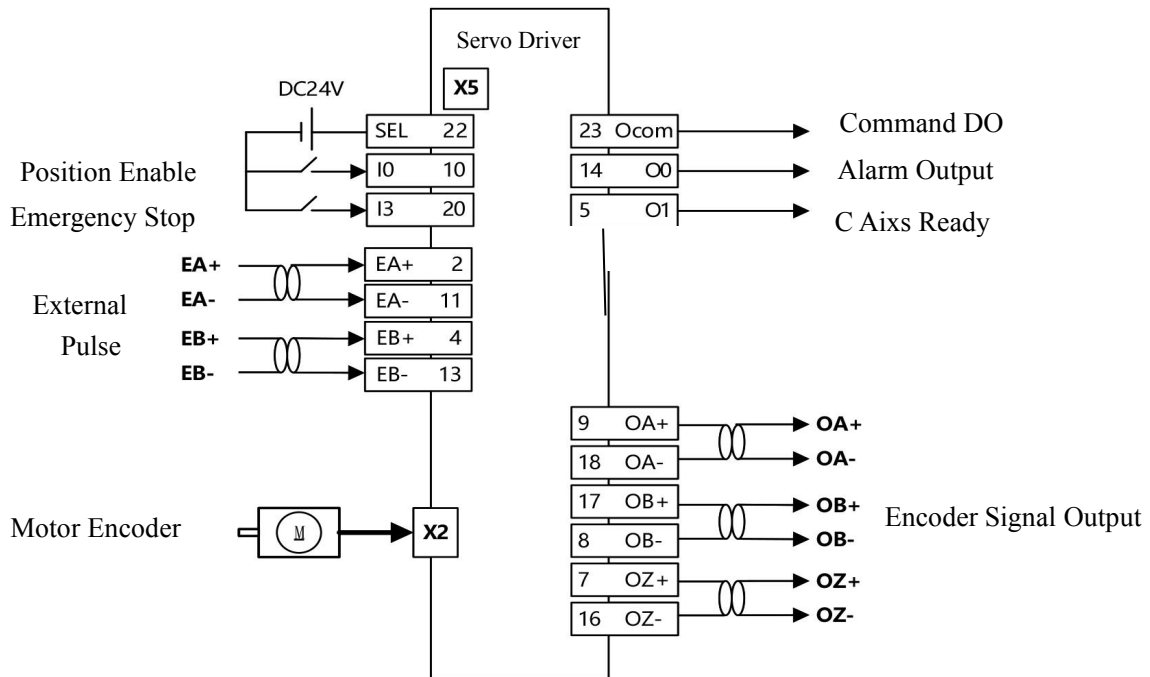

➤ **Parameter Setting:**

Para. No.	mBus Add.	Para.Name	Para. Set	Description
P23_13	0x2372	I3 Input	5	EC
P23_14	0x2374	I4 Input	4	Position Enable
P24_10	0x23B8	O0 Output	0	Alarm Output
P24_11	0x23BA	O1 Output	2	C Axi's ready
P53_02	0x2884	Type of Position Instruction Input	2	External Pulse Input

➤ **Parameter of Pulse Position:**

Para. No.	mBus Add.	Para.Name	Para. Set	Description
P22_01	0x2352	External Pulse Input	0	0:AB Pulse 1:PD Pulse 2:CW Pulse
P53_03	0x2886	Position instruction frequency filtering time	2	
P53_04	0x28AE	Position instruction Acceleration filtering time	30	
P53_10	0x2894	Direction of Position Instruction	0	0: Positive Direction 1: Negative Direction
P53_11	0x28AA	Position instruction gear ratio molecule	1000	
P53_12	0x2884	Position instruction gear ratio master	1000	

5.5.4.2 Instruction Type: ±10 Analog voltage

Wiring Diagram:

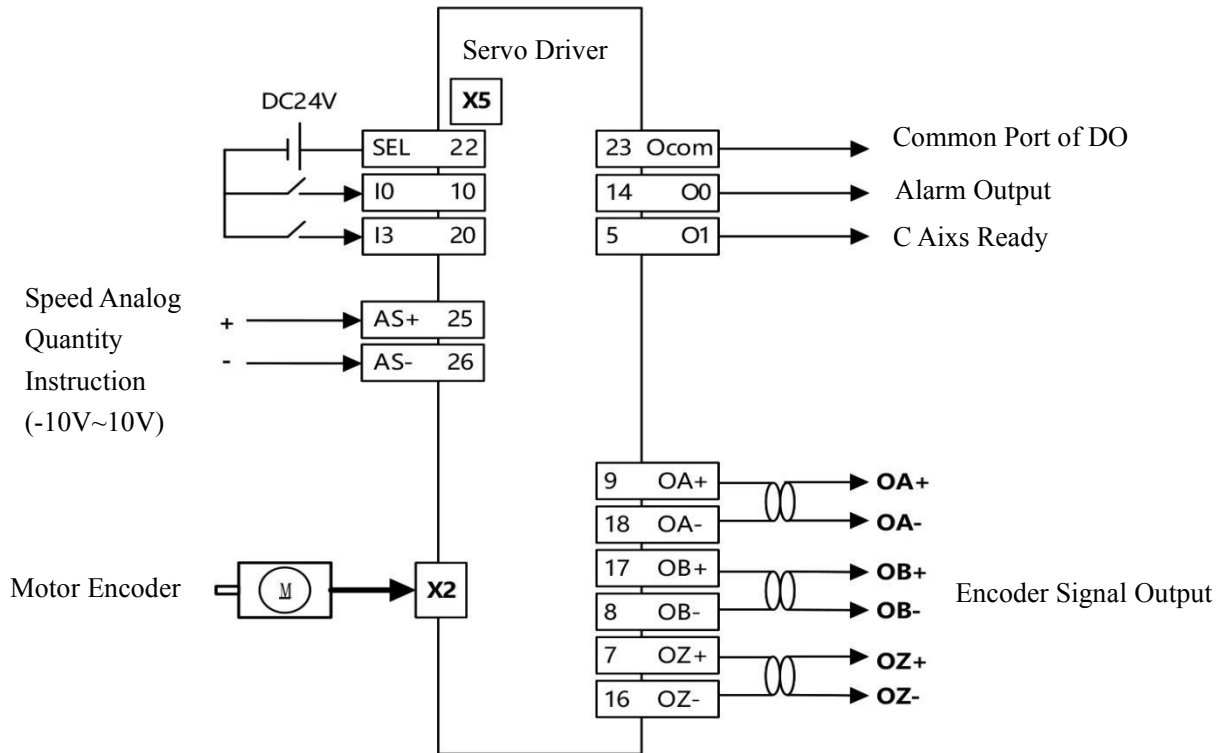

➤ **Parameter Setting:**

Para. No.	mBus Add.	Para.Name	Parameter Setting	Description
P23_13	0x2372	I3 Input definition	5	EC
P23_14	0x2374	I4 Input definition	27	Speed Position Enable
P24_10	0x23B8	O0 Output definition	0	Alarm Output
P24_11	0X23BA	O1Output definition	2	C Aixs Ready
P53_02	0x2884	Type of Position Instruction Input	0	Analog quantity Input

➤ **Parameter of Analog Position Instruction:**

Para. No.	mBus Add.	Para.Name	Parameter Setting	Description
P53_17	0x2372	I3 Input definition	5	EC
P53_19	0x2374	I4 Input definition	27	Speed Position Enable
P53_20	0x23B8	O0 Output definition	0	Alarm Output

5.6 Homing Mode

Homing mode, also quasi-stop, most apply to Tool change of CNC, homing, etc.

5.6.1 Homing Mode

P54_00	Description	Explanation
0	Forward Homing	After find Z pulse, motor rotate forward for homing
1	Backward Homing	After find Z pulse, motor rotate backward for homing
2	Nearby Homing	After zero speed, nearby for homing

5.6.2 Monitored Parameter

Para. No.	mBus Add.	Para.Name	Description
d	0x2364	Digital Input	Digital Input Monitor
P	0x2272	Motor Encoder Count	Unit: pulse
H	0x2274	Motor Axis Absolute Position	Unit: pulse
Ao	0x2228	Motor Output Current	Unit: A
To	0x2238	Motor Output Torque	Unit: Rated Torque Multiple
r	0x2276	Motor Speed	Unit: rpm

5.6.3 Performance Parameter

Para. No.	mBus Add.	Para. Name	Range	Default	Unit
P54_02	0x2904	Accurate Stop Dec	0~1000	50	Hz/s
P54_03	0x2906	Accurate Stop Search Z Speed	0~200	100	rpm
P54_04	0x2920	Accurate Stop Pos Max Speed	0~200	100	rpm
P54_07	0x290E	Accurate Stop Stiff	0.0001~0.1	0.001	-
P54_10	0x2914	Accurate Stop Precision	0~100	2	Pulse

5.6.4 Origin Signal(Z Pulse) Parameter

Para. No.	mBUS Add.	Para. Name	Range	Default	Unit
P15_00	0x2280	Z Phase Input	0:Motor Encoder Z;1 : External Z		
P15_01	0x2282	Z Pulse Width	0~100	1	Pulse

5.6.5 Trigger of Homing

Para. No.	mBUS Add.	Para. Name	Range	Default	Unit
P51_02	0x2824	Trigger Type of Homing	0:High, 1:Pulse Effective /Input Change Power off		

There are three type of trigger homing as follow:

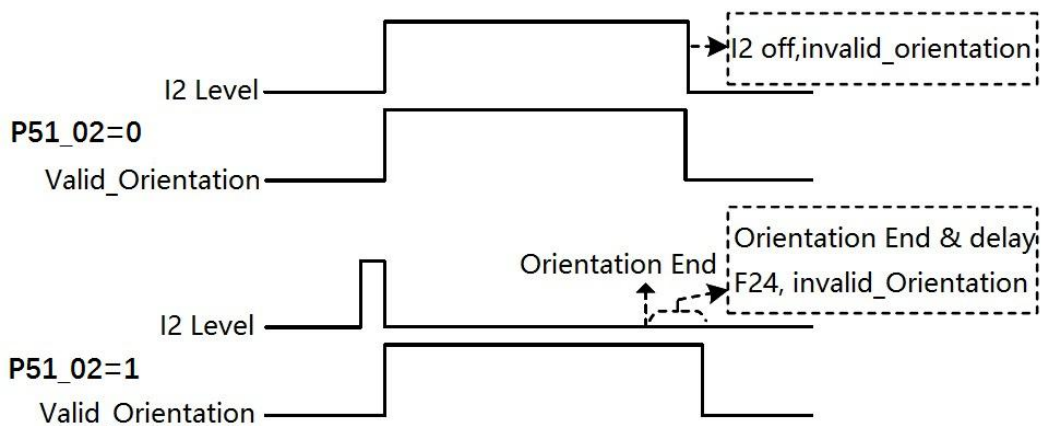

5.6.6 Homing Movement Parameter

Para. No.	mBus Add.	Para. Name	Range	Default	Unit
P54_02	0x2904	Deceleration at Homing	0~1000	20	Hz/s
P54_07	0x290E	Positioning Gain at Homing	0.0001~0.1	0.001	-
P54_03	0x2906	Speed at Searching Z pulse	1~200	60	rpm
P54_10	0x2914	Monitoring Precision of Homing	0~100	2	pulse
P54_12	0x2918	Position of 1st Homing	0x8000000~0x7FFF FFFFF	1000	pulse
P54_13	0x291A	Position of 2nd Homing	0x8000000~0x7FFF FFFFF	1000	pulse
P54_14	0x291C	Position of 3rd Homing	0x8000000~0x7FFF FFFFF	1000	pulse
P54_15	0x291E	Position of 4th Homing	0x8000000~0x7FFF FFFFF	1000	pulse

➤ Driver provide 4 types of homing which can be triggered by I2, I9, I11 & I12.

5.6.7 Example

5.6.7.1 Homing Mode: Forward Looking for Z Quasi-stop

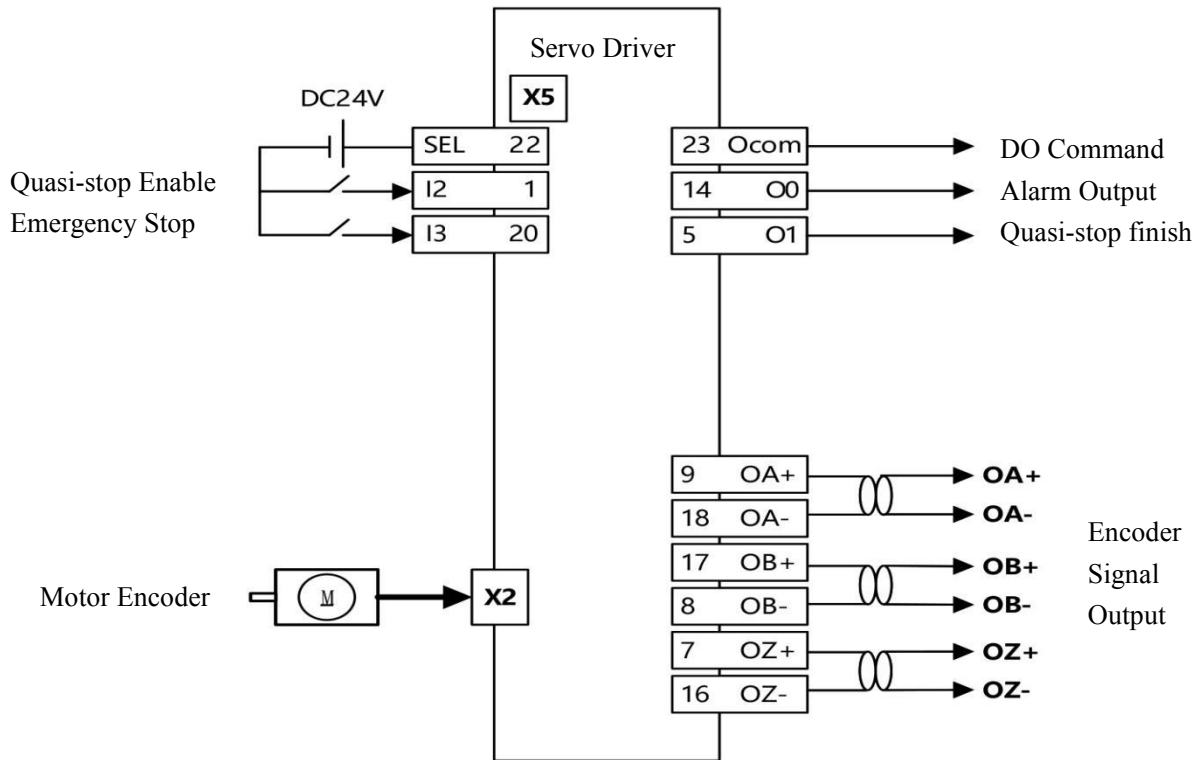

➤ **Parameter Setting:**

Para. No.	mBus Add.	Para. Name	Parameter	Description
P23_12	0x2370	I2 Input Definition	2	Quasi-stop Enable
P23_13	0x2372	I3 Input Definition	5	Emergency Stop
P24_10	0x1117	O0 Output Definition	0	Alarm Output
P24_11	0x1118	O1 Output Definition	1	Quasi-stop finish

➤ **Parameter of Quasi-stop Instruction:**

Para. No.	mBus Add.	Para. Name	Parameter	Description
P54_12	0x2918	Adjust the 1 st Quasi-stop Position	2000	The number of Quasi-stop aim Position
P51_02	0x2824	Input Type of triggered by Quasi-stop	0	High Level Valid
P54_00	0x2900	The choice of Quasi-stop Mode	0	0:Forward Quasi-stop 1:Reverse Quasi-stop 2:Quasi-stop Nearby

➤ **The example picture:**

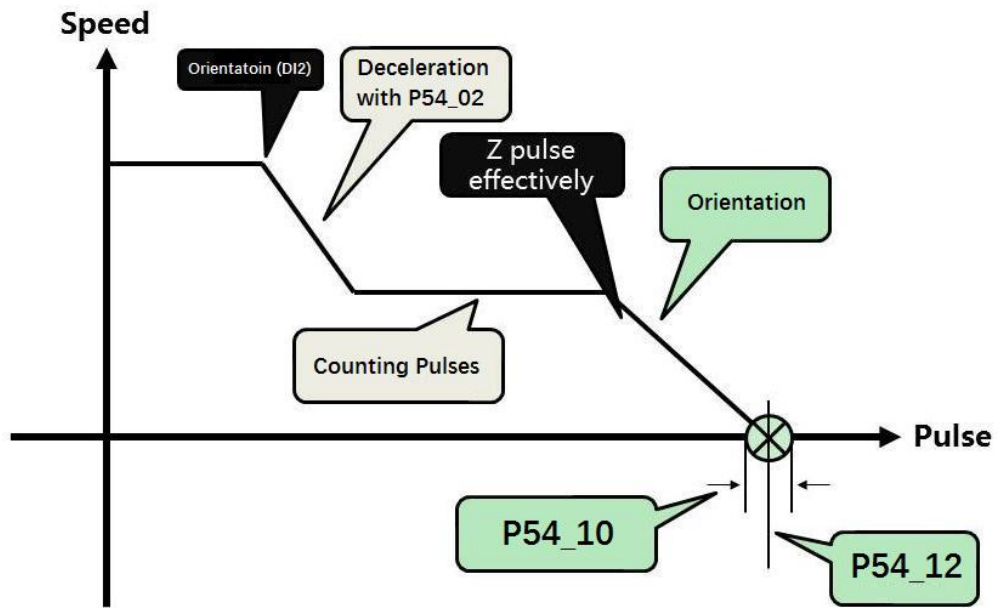

➤ **The explain of quasi-stop step:**

- 1) The driver receive the signal of quasi-stop be triggered and then get into the process.
- 2) Please decelerate to the number displayed on P54_03 that regard P54_02 as deceleration if the rotation of the number displayed on driver is high.
- 3) Please accelerate to the number displayed on P54_03 that regard P54_02 as acceleration if the rotation of the number displayed on driver is 0.
- 4) Driver forward rotate to find the Pulse of Z which the speed set by P54_03.
- 5) Positioning rigidity which at the process of entering quasi-stop after find Z pulse depends on P54_07.
- 6) After finding Z pulse, the motor will run with the control of driver(The number of Pulse set by P54_12 on driver) and the precision depend on P54_10(Parameter on Driver).
- 7) Driver will display Err-24 if execute quasi-stop over 10 seconds.
- 8) Whether the quasi-stop signal output, it depends on that whether the value which is displayed on the screen at the range of the number set by P54_12.

5.6.7.2 Quasi-stop Mode: Proximity Principle

➤ The wire connection of nearby quasi-stop as same as quasi-stop for find Z.

➤ The parameter of Quasi-stop Instruction:

Para. No.	mBUS Add.	Para.Name	Set Value	Description
P54_12	0x2918	Adjust the 1st quasi-stop position	2000	Value of quasi-stop position
P51_02	0x2824	Type of quasi-stop input	0	Valid at high level
P54_00	0x2900	Chosen of quasi-stop mode	2	0: Forward quasi-stop 1: Reverse quasi-stop 2:Nearby quasi-stop

➤ The example picture:

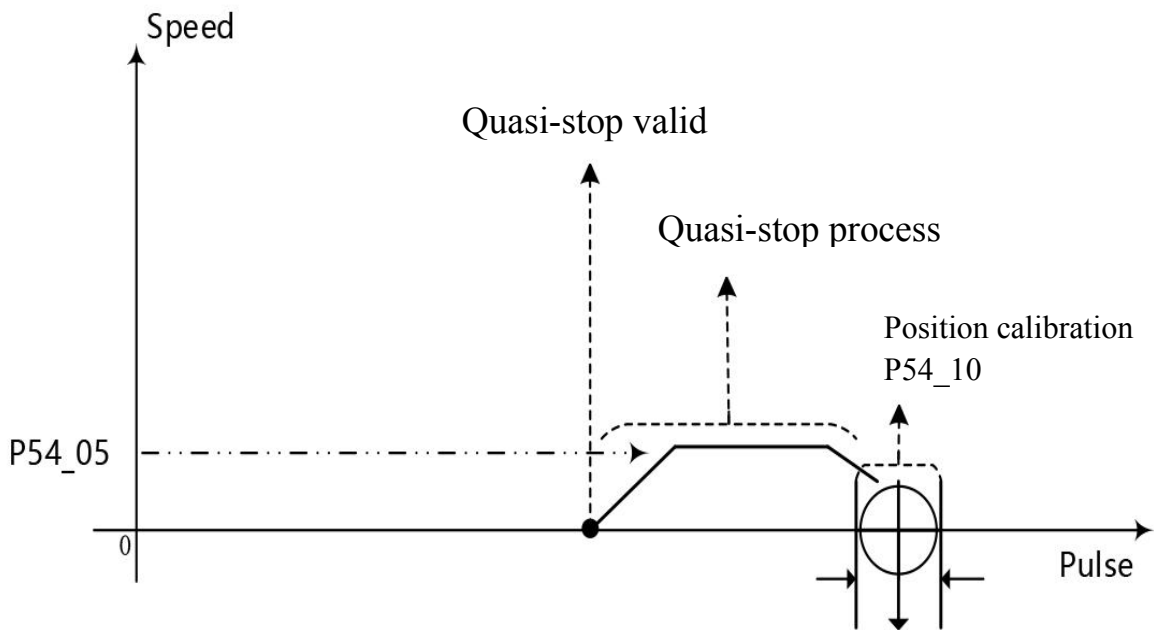

➤ The detailed step of quasi-stop:

- 1) Entering the process when driver receives the signal of start quasi-stop.
- 2) The quasi-stop mode depends on whether Z pulse signal is received; if not, driver will chose forward Z pulse quasi-stop mode; if yes, driver will chose nearby quasi-stop.
- 3) The value that the distance between the current position of motor and Z signal is Real-time absolute position of motor shaft which feedback by driver after received a Z pulse signal every time, you can check it on monitoring parameter H.
- 4) At the process of quasi-stop, please do acceleration at the speed of P54_12 if the value of speed displayed on driver is so high, then go on doing quasi-stop.
- 5) Doing quasi-stop directly when the speed displayed on driver is 0.
- 6) At the process of quasi-stop, the distance and direction of motor controlled by driver, the value decided on the comparison between current H and P54_12. Positioning rigidity decided on P54_07, precision decided on P54_12.
- 7) If the process of quasi-stop over time more than 10s, it will ERR-24.
- 8) Whether the quasi-stop signal output, it depends on that whether the value which is displayed on the screen at the range of the number set by P54_12.

5.7 Torque Control

It always used in tension control, drawing and unwinding, packaging printing and textile machinery control.(please remark this function with us before order)

5.7.1 Instruction source

- All the source of torque control decided on parameter P56_00.

P56_00	Description	Explain
0	Analog quantity torque instruction: 0~10V	AS+ and AS- input analog voltage
1	Analog quantity torque instruction: $\pm 10V$	AS+ and AS- input analog voltage
2	Pulse torque instruction: external pulse	Pulse frequency of EA+, EA-, EB+, EB-.
3	BUS torque instruction: mBUS	X0/X1 set target torque

5.7.2 Monitoring parameter

Para. No.	mBUS Add.	Para.Name	Description
d	0x2364	Digital input	I point do Monitor
A1	0x2318	Corrected analog input	Unit: V
Fo	0x24A0	Motor output frequency	Unit: HZ
Ao	0x2228	Motor output electricity	Unit: A
To	0x2238	Motor output torque	Unit: Rated torque multiple
r	0x2276	Motor rotation speed	Unit: rpm

5.7.3 Performance Parameter

Para.	mBUS Add.	Para.Name	Range	Value	Unit
P56_01	0x2A02	Max Torque	0~3	2	Rated Torque Multiple
P56_02	0x2A04	Torque Acceleration	0.01~10	1	Rated Torque Multiple/s
P56_03	0x2A06	Torque Deceleration	0.01~10	1	Rated Torque Multiple/s
P56_05	0x2A0A	Forward Attenuation Speed of Torque Ring	0~30000	1500	rpm
P56_06	0x2A0C	Reverse Attenuation Speed of Torque Ring	0~30000	1500	rpm
P56_07	0x2A0E	Forward overspeed attenuation rate of torque ring	0~10	0.1	Rated Torque Multiple/HZ
P56_08	0x2A10	Reverse overspeed attenuation rate of torque ring	0~10	0.1	Rated Torque Multiple/HZ
P56_09	0x2A12	Torque overspeed attenuation speed step	0~10	10	rpm

5.7.4 Torque Direction

Number	P56_04	Description
1	0	$t_q = t_q$
2	1	$t_q = -t_q$

5.7.5 Torque Acceleration/Deceleration

Para. No.	mBUS Add.	Para.Name	Set Value	Unit
P56_02	0x2A04	Torque acceleration of ring	1	Rated Torque Multiple/HZ

➤ **Formula of torque acceleration and deceleration time in torque control:**

$$t = \frac{|T_{q1} - T_{q2}|}{P56_04}$$

➤ Note:1. T_{q1} is current torque, T_{q2} is target torque, t is acceleration time(s).

3. $T_q=1$ delegate rating, $T_q=2$ is double rating.

5.7.6 Torque Anti-overspeed

Para. No.	mBUS Add.	Para.Name	Set Value	Description
P56_05	0x2A0A	Forward Attenuation Speed of Torque Ring	1000	rpm
P56_06	0x2A0C	Reverse Attenuation Speed of Torque Ring	1000	rpm
P56_07	0x2A0E	Forward overspeed attenuation rate of torque ring	0.1	Rated Torque Multiple/s
P56_08	0x2A0E	Reverse overspeed attenuation rate of torque ring	0.1	Rated Torque Multiple/s
P56_09	0x2A12	Torque overspeed attenuation speed step	10	rpm

➤ In order to prevent ‘overspeed’ in torque control, the output torque will automatic reduce by the value of P56_06 when motor speed ‘r’ greater than the value.

$$\text{Forward overspeed: } T_{q(actual)} = \left(T_{q(target)} - \frac{|r - P56_05| * P56_07}{P56_09} \right) > 0$$

$$\text{Reverse overspeed: } T_{q(actual)} = \left(T_{q(target)} + \frac{|r - P56_06| * P56_08}{P56_09} \right) < 0$$

5.7.7 Example

5.7.7.1 Type of instruction: ±10V analog voltage

The wire diagram:

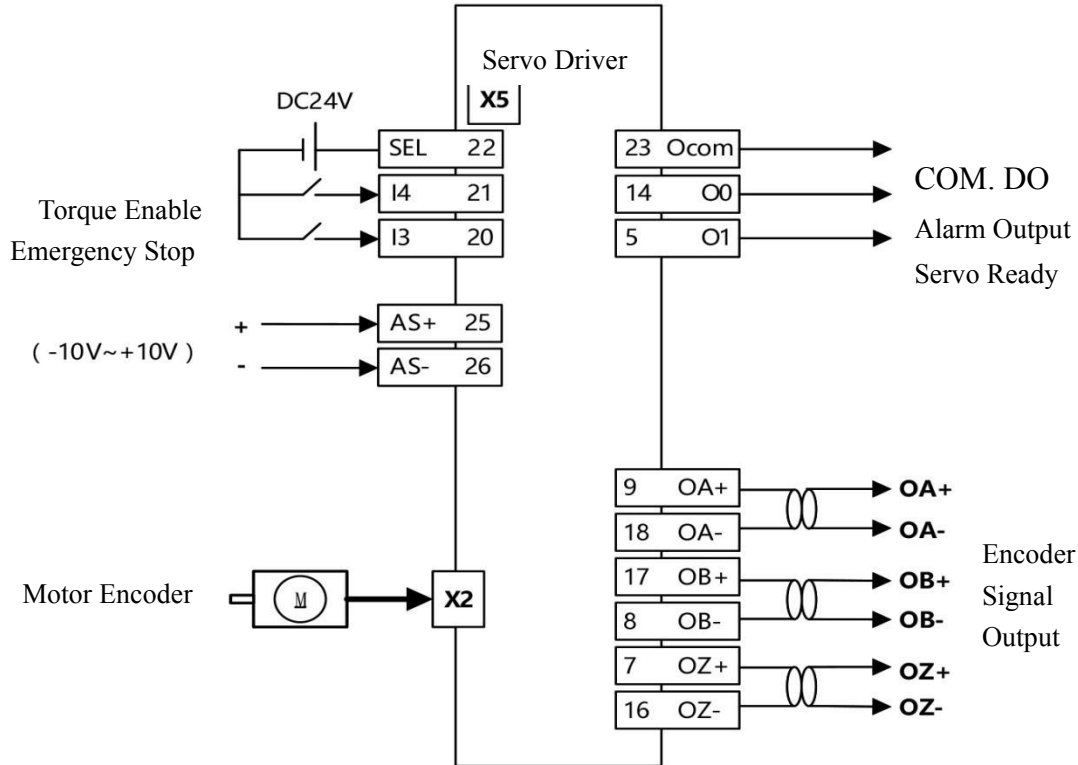

➤ Parameter Setting:

Para. No.	mBUS Add.	Para.Name	Set Value	Description
P23_10	0x236C	I0 input definition	10	Torque enable
P23_13	0x2372	I3 input definition	5	Emergency stop
P24_10	0x23B8	O0 output definition	0	Alarm output
P24_11	0x23BA	O1 output definition	4	Servo ready
P56_00	0x2A00	Type of torque instruction input	0	Analog quantity input(Torque)

➤ Parameter of analog Torque Instruction:

Para. No.	mBUS Add.	Para.Name	Set Value	Description
A1	0x2318	Corrected analog quantity input		
P56_01	0x2A02	10V corresponding MAX torque instruction	Adaption	Rated Torque multiple

➤ Torque formula: $(0 \leq |T_q| \leq P56_01)$

$$T_q = \frac{A1}{10.000} * P56_01$$

5.7.7.2 Type of instruction: mBUS

The wire diagram:

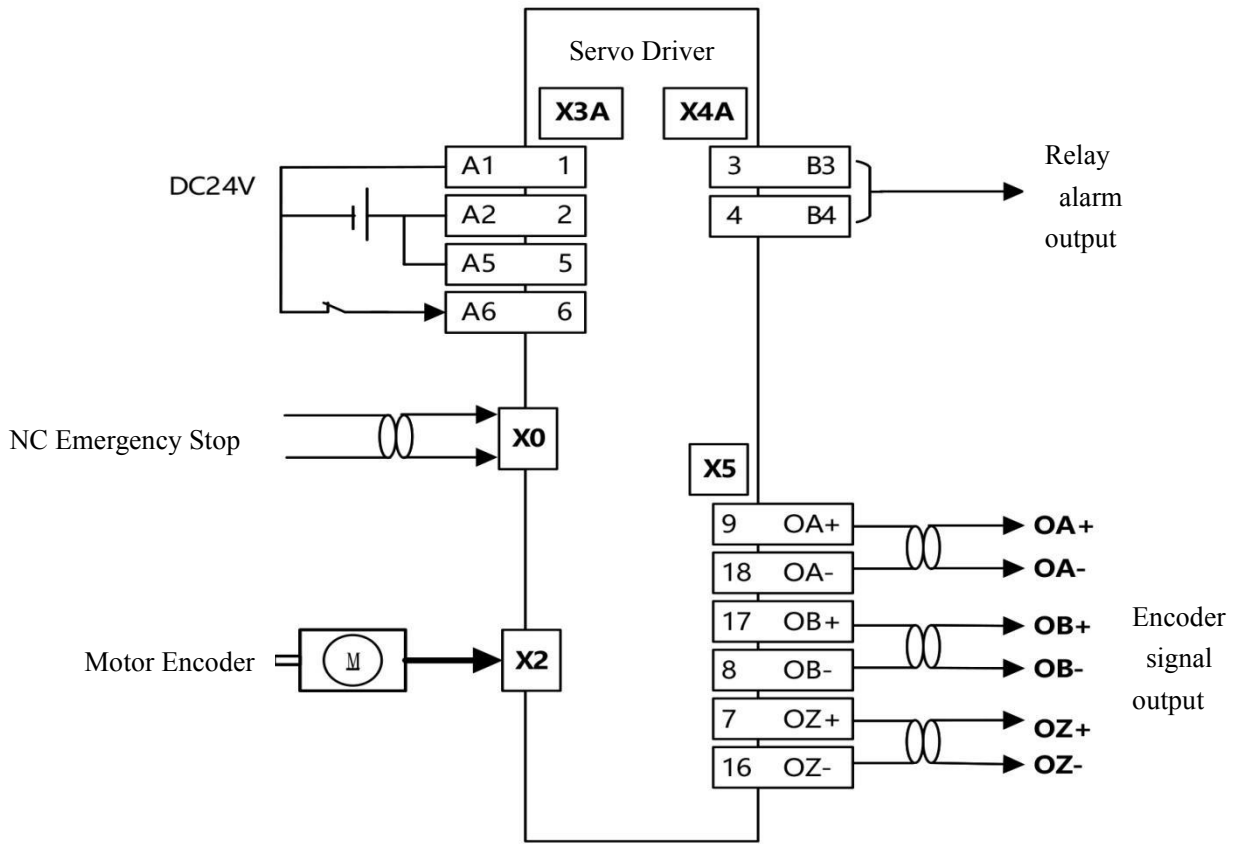

➤ **Parameter Setting:**

Para. No.	mBUS Add.	Para.Name	Set Value	Description
P23_16	0x2378	I6 input definition	5	Emergency Stop
P24_14	0x23C0	O4 output definition	0	Alarm output
P56_00	0x2A00	Type of Torque instruction input	3	mBUS

➤ **mBUS Parameter:**

Para. No.	mBUS Add.	Para.Name	Set Value	Description
P23_30	0x238C	mBUS digital input	10	Valid
P56_10	0x2A14	mBUS torque instruction value	Adaption	Rated torque multiple

➤ **Formula: $(0 \leq |t_q| \leq P56_01)$**

$$t_q = P56_10$$

5.8 Swing/JOG

➤ Parameter of Example:

Para. No.	mBUS Add.	Para.Name	Set Value	Description
P23_10	0x236C	I0_Definition	8	JOG
P23_11	0x236E	I1_Definition	6	Swing
P23_13	0x2372	I3_Definition	5	Emergency Stop
P24_10	0x23B8	O0_Definition	0	Warning Output
P24_11	0x23BA	O1_Definition	4	Servo Ready

Note: Motor JOG forward only when JOG IO is effective; motor swing only when swing IO is effective; Motor JOG backward when both IO are effective.

➤ Speed Parameter of Swing/JOG:

Para. No.	mBUS Add.	Para.Name	Set Value	Description
P58_00	0x2A60	Swing Angle	180	°
P58_01	0x2A62	Swing Speed	60	rpm
P57_00	0x2A40	JOG Speed	60	rpm
P57_01	0x2A42	JOG Acceleration	20	Hz/s

5.9 Switching Control of Two-speed motor

The driver can control the switching of double base speed servo motor. Two-speed motor can out large torque at the range of low speed, as to in high speed range, the constant power range is wide, which frequency can reach 15 times of low speed. Two-speed motor, a good substitute of two-speed reducer which can shift gear automatically, widely used in rough machining and finish machining concurrently, such as, faucet, gantry milling, machining center and so on.. The speed shift of two-speed motor need shift the contactor to be come true, whether shift by power off, shift by system control when power on or shift when reach the speed automatically can complete the operation.

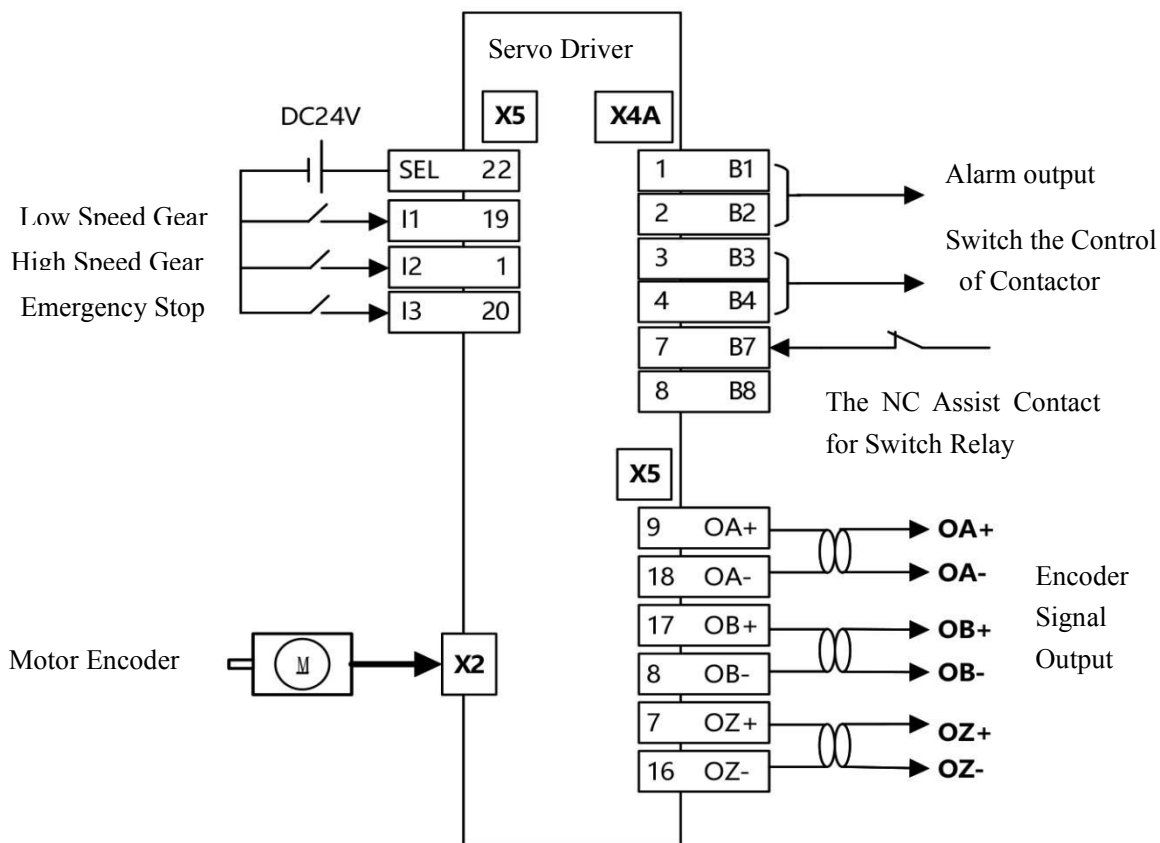

➤ **Parameter Set:**

Para. No.	mBUS Add.	Para.Name	Set Value	Description
P23_11	0x236E	I1_Definition	14	Switch to Low Speed
P23_12	0x2370	I2_Definition	22	Switch to High Speed
P23_17	0x237A	I7_Definition	15	Switch Mark
P24_14	0x23C0	O4_Definition	0	Alarm Output
P24_15	0x23C2	O5_Definition	6	Two-speed Switch
P03-04	0x2188	Chose the Switch mode of Two-speed Contactor	1	0:Input Invalid is Low Speed(NO Assist contact) 1:Input Invalid is Low Speed(NC Assist contact) 2:Input Invalid is High Speed(NO Assist contact) 3:Input Invalid is High Speed(NO Assist contact)

➤ **Parameter Set of Two-speed Switching:**

5.9.1 Motor Wiring Diagram

- Wire of Two-speed motor consists of six lead-out line, they are U1, V1, W1,U2, V2, W2.
- Two-speed motor have two type of wire diagram,triangle type connection(High Speed Gear) and star type connection(Low Speed Gear), it can change by the switching of contactor.
- Switching the contactor need to be interlocking mode, there are the picture of wire diagram:

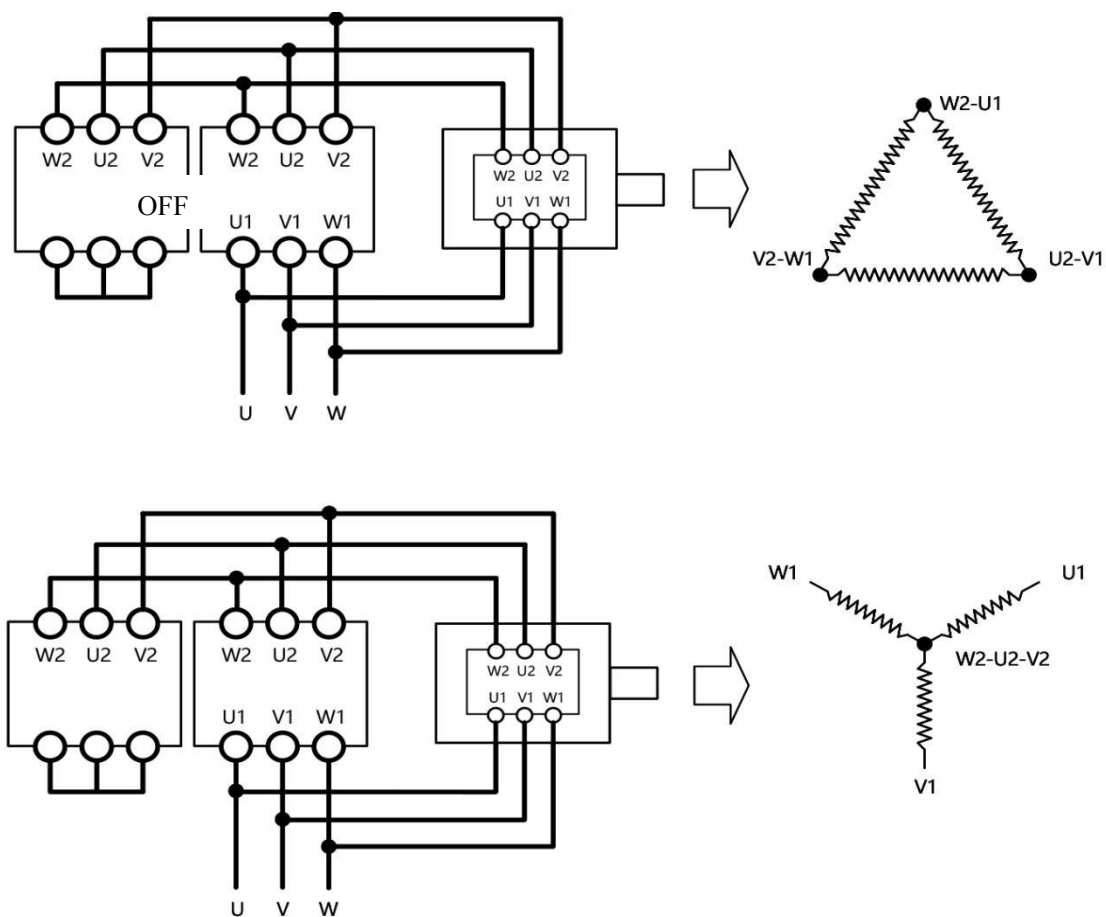

5.9.2 Switching Status Table

Status (Speed)	I1	I2	Switching Action	Two-speed Switching O5	Mark	Status after Switching
If switching contactor has a NC auxiliary contact When the contact invalid, it is at Low Speed Gear When the contact valid, it is at High Speed Gear: Parameter P30_04 need to be set to 1						
Low	0	1	Low>High	1	0	High speed
High	1	0	High>Low	0	1	Low speed
Low	0	1	Low>High	1	1	Err-18
High	1	0	Low>High	0	0	Err-18

Status (Speed)	I1	I2	Switching Action	Two-speed Switching O5	Mark	Status after Switching
If switching contactor has a NO auxiliary contact When the contact invalid, it is at High Speed Gear When the contact valid, it is at Low Speed Gear: Parameter P30_04 need to be set to 2						
Low	0	1	Low>High	0	0	High speed
High	1	0	High>Low	1	1	Low speed
Low	0	1	Low>High	0	1	Err-18
High	1	0	High>Low	0	1	Err-18

Chapter 6 Parameter

6.1 Parameter Summary

Servo driver mainly contains two kinds of parameter: monitored parameter and system parameter (P series)

6.1.1 Monitored Parameter

Code	mBUS Add.	Name of Parameter	Range	Default	Unit
RUN	0x2404	Running of Math	-1: Alarm , 0:Stop , 1: Run		
Ao	0x2228	Motor Output Current	0~65535	0	A
To	0x2238	Motor Output Torque	-4~4	0	%
FI	0x2408	Motor Command Frequency	-50000~50000	0	Hz
Fo	0x240A	Motor Output Frequency	-50000~50000	0	Hz
Fr	0x2276	Motor Speed	-32768~32767	0	rpm
d1~d8	0x2364	Digital Input Monitor	U128	0	-
o1~o4	0x23B0	Digital Output Monitor	U128	0	-
A0	0x2316	Non-revised Analog Input value	-12000~12000	0	V
A1	0x2318	Corrected Analog Input Value	-12000~12000	0	V
P	0x2272	Motor Encoder Counter	I32	0	Pulse
H	0x2274	Motor Axis Absolute Position	I32	0	Pulse
E	0x2356	External Pulse Counting	I32	0	Pulse
F	0x2358	External Pulse Frequency	I32	0	Hz
C	0x240C	Position Coding Pulse	I32	0	Pulse
L	0x240E	Position Coding Frequency	0~0	0	Pulse
U	0x2410	Position Following Error	-32768~32767	0	Pulse
nc	0x2804	Motor Setting Speed (Panel Control)	0~65535	0	rpm
Ac	0x2806	Motor Acceleration (Panel Control)	0~65535	0	Hz/s
dc	0x2808	Motor Deceleration (Panel Control)	0~65535	0	Hz/s
FE	0x280A	Motor Rotate Direction (Panel Control)	0~1	0	-
oP	0x2800	Control Mode	0:IO Control, 1: Panel Control, 2:Phase Selfchck		
Er0	0x4102	No.0 Error	0~65535	0x01FF	-
Er1	0x4120	No.1 Error	0~65535	0x01FF	-
Er2	0x413E	No.2 Error	0~65535	0x01FF	-
Er3	0x415C	No.3 Error	0~65535	0x01FF	-
Er4	0x417A	No.4 Error	0~65535	0x01FF	-
Er5	0x4198	No.5 Error	0~65535	0x01FF	-

6.1.2 System Parameter (P series)

Code	Add.	Name of Parameter	Range	Default	Unit
P01_00	0x2100	Serial Number of Motor Type	0~999999	0	-
P01_01	0x2102	Poles Number of Motor	0~64	4	-
P01_02	0x2104	Rated Frequency of Motor	0~1000	50	Hz
P01_03	0x2106	Max Frequency of Motor	0~1000	500	Hz
P01_04	0x2108	Motor Rated Voltage	1~3000	380	V
P01_05	0x210A	Motor Rated Current	0~1000	13	A
P01_06	0x210C	Motor Rated Torque	0~5000	35	N.m
P01_07	0x210E	Rated Excitation Current of Motor	0~1000	5	A
P01_08	0x2110	Excitation Current Coefficient of Motor	0.01~1.5	0.2	-
P01_09	0x2112	Weak Magnetic Coefficient of Motor	0.01~1	0.1	-
P01_10	0x2114	Motor Moment Of Inertia	0~99.9999	0.1	kgm ²
P01_11	0x2116	Motor Zero Speed Torque Multiple	0.1~4	2	-
P01_12	0x2118	Motor Rated Torque Multiple	0.1~4	2	-
P01_13	0x211A	Motor Constant Power Max Speed	0~50000	4500	rpm
P01_14	0x211C	Motor Zero Slip Compensate Coef	0~10	1	-
P01_15	0x211E	Motor Rated Slip Compensate Coef	0~10	1	-
P01_16	0x2120	Motor Max Slip Compensate Coef	0~30	6	-
P01_17	0x2122	Motor Max Slip Compensate Coef Speed	0~50000	4500	rpm
P02_00	0x2140	Hi Motor SN	0~0	0	-
P02_01	0x2142	Motor Pole Number (H)	0~64	0	-
P02_02	0x2144	Motor Rated Frequency (H)	0~1000	50	Hz
P02_03	0x2146	Motor Max Frequency (H)	0~1000	200	Hz
P02_04	0x2148	Motor Rated Voltage (H)	1~3000	380	V
P02_05	0x214A	Motor Rated Current (H)	0~1000	13	A
P02_06	0x214C	Motor Rated Torque (H)	0~5000	35	N.m
P02_08	0x2150	Motor Flux Current Coff (H)	0.01~1.5	0.2	-
P02_09	0x2152	Motor Rated Flux Weak Coff (H)	0.01~1	0.1	-
P02_10	0x2154	Motor Moment Of Inertia (H)	0~100	0.1	kgm ²
P02_11	0x2156	Motor Zero Speed Torque Multiple (H)	0.1~4	2	-
P02_12	0x2158	Motor Rated Torque Multiple (H)	0.1~4	2	-
P02_14	0x215C	Motor Zero Slip Compensate Coff (H)	0~10	1	-
P02_15	0x215E	Motor Rated Slip Compensate Coff (H)	0~10	1	-
P02_16	0x2160	Motor Max Slip Compensate Coff (H)	0~20	6	-
P02_17	0x2162	Motor Max Slip Compensate Coff Speed	0~50000	4500	rpm
P03_00	0x2180	Double Switch State	0: low gear, 1: high gear		

P03_01	0x2182	Double Switch Type	<p>0: Switch to the I, and switching is only allowed when the power is off</p> <p>1: Switch according to the I, switching when the power is on is allowed.</p> <p>2: Switch according to the when the power is off. Switch when the power is on: not allowed when emergency stop, position control, accurate stop.</p>		
P03_02	0x2184	IGB Toff Cur Attenuation Time	0~10000	20	Ms
P03_03	0x2186	Switch Relay Switch Time	1~10000	1000	Ms
P03_04	0x2188	Double Switch Relay Type			
P03_05	0x218A	Double Switch Speed	0~1000	50	Hz
P10_00	0x2200	Driver SN	0~999999	0	-
P10_01	0x2202	Driver Rated Voltage	1~3000	380	V
P10_05	0x220A	Driver Over Ambient Temp	35~85	55	°C
P10_06	0x220C	Driver Ambient Temp	0~0	0	°C
P11_00	0x2220	Current Sensor	0~5000	100	A
P11_01	0x2222	Cur Zero Error Range (H)	2000~2150	2100	ADC value
P11_02	0x2224	Cur Zero Error Range Low	1950~2100	2000	ADC value
P11_03	0x2226	Cur Hard Protect Threshold	0.1~1.5	1.2	IGBT Rated times
P11_04	0x2228	Output Cur Rms	-	0	A
P11_05	0x222A	Output Cur Rms Filter Time	10~300	100	ms
P11_06	0x220C	Number of overcurrent alarm	1~9	2	-
P12_00	0x2230	Motor Over Load Protect Multiple	0.1~3	1.5	*Rated torque
P12_01	0x2232	Motor Over Load Counter Time Max	1~100000	1000	s
P12_04	0x2238	Motor Output Torque Multiple	0~0	0	*Rated torque
P12_05	0x223A	Motor Output Torque	0~0	0	N.m
P12_06	0x223C	Motor Output Torque 16 Sector	0.01~5	0	*Rated torque
P12_07	0x223E	Motor Warn Load	0.001~3	2	*Rated torque
P12_08	0x2240	Motor Warn Load	1~100000	20	s
P12_09	0x2242	Motor Warn Load Power Down	0: power on, 1: power off		
P12_10	0x2244	Excitation Current Establishment Time	0~1000	240	ms
P12_11	0x2246	Speed Drop Rate	0~100	0	%

P13_00	0x2250	Udc K	-0.66~0.62	-0.64051241	-
P13_01	0x2252	Udc B	1380~1384	1382.22578	-
P13_02	0x2254	Udc Th Over	0~5000	800	V
P13_03	0x2256	Udc Th Under	0~5000	390	V
P13_04	0x2258	Udc Brake On	0~5000	700	V
P13_05	0x225A	Udc Brake Hysteresis	0~500	40	V
P13_06	0x225C	Udc Display	0~0	0	V
P14_00	0x2260	Motor Encoder Type	0: No Encoder, 1: Optical-electricity Encoder, 2: Incremental rotary transformer 3: Incremental magnetoresistor encoder, 10: Absolute type rotary transformer, 20:BISS Bus encoder 30: Sin-Cos Encoder		
P14_01	0x2262	Motor Resolution Per Revolution	1~100000000	1024	-
P14_02	0x2264	Motor Multi Turn Encoder Line Number	1~100000000	0	-
P14_03	0x2266	Motor Encoder Direction	0~1	0	-
P14_04	0x2268	Motor Encoder Low Speed Measure Shift Point	0~999	0	Pulse
P14_05	0x226A	Motor Encoder Pos Filter Time	1~30	2	ms
P14_06	0x226C	Motor Encoder Speed Filter Time	1~50	3	ms
P14_07	0x226E	Motor Encoder Zero Filter Time	1~10	1	ms
P14_08	0x2270	Motor Encoder Lost Line Time Threshold	0~10	2	s
P14_09	0x2272	Motor Encoder Counter	0~0	0	Pulse
P14_10	0x2274	Motor Encoder Abs Position	0~0	0	Pulse
P14_11	0x2276	Motor Encoder Speed Rpm Display	0~0	0	rpm
P15_00	0x2280	Zero Source	0: encoder Z0, 1: external Z0, 2: double Z		
P15_01	0x2282	Zero Source Width	0~100	1	Pulse
P15_02	0x2284	Zero Pulse Valid Counter	0~0	0	-
P15_03	0x2286	Encoder Output Source	0: Motor Encoder, 1: 2nd Encoder		
P15_04	0x2288	Encoder Output Line Number	1~100000000	1024	-
P16_00	0x22A0	Second Encoder Type	0:No Encoder,1: Optical-electricity Encoder		
P16_01	0x22A2	2nd Single Turn Encoder Line Number	1~100000000	1024	-

P16_02	0x22A4	2nd Multi Turn Encoder Line Number	1~100000000	0	-
P16_03	0x22A6	2nd Encoder Direction	0~1	0	-
P16_04	0x22A8	2nd Encoder Low Speed Measure Shift Point	0~999	0	Pulse
P16_05	0x22AA	2nd Encoder Pos Filter Time	1~30	2	ms
P16_06	0x22AC	2nd Encoder Speed Filter Time	1~50	3	ms
P16_07	0x22AE	2nd Encoder Zero Filter Time	1~10	1	ms
P16_08	0x22B0	2nd Encoder Lost Filter Time	0~10	2	s
P16_09	0x22B2	2nd Encoder Counter	0~0	0	Pulse
P16_10	0x22B4	2nd Encoder Abs Position	0~0	0	Pulse
P16_11	0x22B6	2nd Encoder Speed Rpm Display	0~0	0	rpm
P20_00	0x2300	ID	0~255	0x30	-
P20_01	0x2302	Uart Baud	-		
P20_02	0x2304	Can Baud	-		
P20_03	0x2306	Select Uart Led	0: OPBK, 1: LEDF		
P21_00	0x2310	External Analog Filter Time	1~100	20	ms
P21_01	0x2312	Ext Analog Adc K	0.009~0.011	0.0101	-
P21_02	0x2314	Ext Analog Adc B	-19~-20.5	-19.766	-
P21_03	0x2316	Pre Corrected Voltage	0~0	0	V
P21_04	0x2318	Corrected Voltage	0~0	0	V
P21_10	0x231A	Correct Sample Voltage_P0	-12~12	0.2	V
P21_11	0x231C	Correct Ins Voltage_P1	-12~12	2	V
P21_12	0x231E	Correct Sample Voltage_P1	-12~12	2	V
P21_13	0x2320	Correct Ins Voltage_P2	-12~12	4	V
P21_14	0x2322	Correct Sample Voltage_P2	-12~12	4	V
P21_15	0x2324	Correct Ins Voltage_P3	-12~12	6	V
P21_16	0x2326	Correct Sample Voltage_P3	-12~12	6	V
P21_17	0x2328	Correct Ins Voltage_P4	-12~12	8	V
P21_18	0x232A	Correct Sample Voltage_P4	-12~12	8	V
P21_19	0x232C	Correct Sample Voltage_P10	-12~12	10	V
P21_20	0x232E	Correct Sample Voltage_N0	-12~12	-0.2	V
P21_21	0x2330	Correct Ins Voltage_N1	-12~12	-2	V
P21_22	0x2332	Correct Sample Voltage_N1	-12~12	-2	V
P21_23	0x2334	Correct Ins Voltage_N2	-12~12	-4	V

P21_24	0x2336	Correct Sample Voltage_N2	-12~12	-4	V
P21_25	0x2338	Correct Ins Voltage_N3	-12~12	-6	V
P21_26	0x233A	Correct Sample Voltage_N3	-12~12	-6	V
P21_27	0x233C	Correct Ins Voltage_N4	-12~12	-8	V
P21_28	0x233E	Correct Sample Voltage_N4	-12~12	-8	V
P21_29	0x2340	Correct Sample Voltage_N10	-12~12	-10	V
P22_00	0x2350	Ext Pulse Filter Time	1~100	5	ms
P22_01	0x2352	Ext Pules Type	0: AB type, 1: PD Type 1, 2: CW Type 3:PD Type 2		
P22_02	0x2354	Ext Pules Dir	0: Forward Direction 1: Reverse		
P22_03	0x2356	Ext Pules Value	0~0	0	Pulse
P22_04	0x2358	Ext Pules Frequency	0~0	0	Hz
P22_05	0x235A	Number of lines of external pulse frequency reference encoder	1~100000 000	1024	
P23_00	0x2360	Input Filter Time	1~100	10	ms
P23_01	0x2362	Input Filter Window	1~16	3	-
P23_02	0x2364	Di Ins 1	0~0	0	-
P23_03	0x2366	Di Ins 2	0~0	0	-
P23_04	0x2368	Di Ins 3	0~0	0	-
P23_05	0x236A	Di Ins 4	0~0	0	-
P23_10	0x236C	Input MapToDi 0	0: Speed Forward; 1: Speed Backward; 2: Homing 0; 3: Homing 1; 4: Position Control; 5: Emergency Stop; 6: Swing; 7: Reset; 8: JOG 9: JOG Backward; 11: Homing 2; 12: Homing 3; 13: Motor Overheat; 14: Double Speed Switch(HighSpeed) 15: Double Speed Switch(Low Speed) 16: Double Speed Switch Relay Flag;		
P23_11	0x236E	Input MapToDi 1			
P23_12	0x2370	Input MapToDi 2			
P23_13	0x2372	Input MapToDi 3			
P23_14	0x2374	Input MapToDi 4			
P23_15	0x2376	Input MapToDi 5			
P23_16	0x2378	Input MapToDi 6			
P23_17	0x237A	Input MapToDi 7			
P23_18	0x237C	Input MapToDi 8			
P23_19	0x237E	Input MapToDi 9			
P23_20	0x2380	Input MapToDi 10			
P23_21	0x2382	Input MapToDi 11			
P23_22	0x2384	Input MapToDi 12			

P23_23	0x2386	Input MapToDi 13			
P23_24	0x2388	Input MapToDi 14			
P23_25	0x238A	Input MapToDi 15			
P23_30	0x238C	Mbus Input 1	0~0XFFF	0	-
P23_31	0x238E	Mbus Input 2	0~0XFFF	0	-
P23_32	0x2390	Mbus Input 3	0~0XFFF	0	-
P23_33	0x2392	Mbus Input 4	0~0XFFF	0	-
P24_00	0x23B0	Do Ins 1	0~0XFFF	0	-
P24_01	0x23B2	Do Ins 2	0~0XFFF	0	-
P24_02	0x23B4	Do Ins 3	0~0XFFF	0	-
P24_03	0x23B6	Do Ins 4	0~0XFFF	0	-
P24_10	0x23B8	Input MapToDo 0	0: Warn Output; 1: Homing Reach 2: Position Ready; 3: Speed Reach; 4: Servo Ready; 5: Fan Output; 9: Zero speed reach; 127: Invalid *Note: The above number+128 is the normally closed type output		
P24_11	0x23BA	Input MapToDo 1			
P24_12	0x23BC	Input MapToDo 2			
P24_13	0x23BE	Input MapToDo 3			
P24_14	0x23C0	Input MapToDo 4			
P24_15	0x23C2	Input MapToDo 5			
P24_16	0x23C4	Input MapToDo 6			
P24_17	0x23C6	Input MapToDo 7			
P24_18	0x23C8	Input MapToDo 8			
P24_19	0x23CA	Input MapToDo 9			
P24_20	0x23CC	Input MapToDo 10			
P24_21	0x23CE	Input MapToDo 11			
P24_22	0x23D0	Input MapToDo 12			
P24_23	0x23D2	Input MapToDo 13			
P24_24	0x23D4	Input MapToDo 14			
P24_25	0x23D6	Input MapToDo 15			
P24_30	0x23D8	Mbus Output 4	0~0XFFF	0	-
P25_00	0x23E0	Profibus Local Address	10~42	10	-
P25_01	0x23E2	Profibus Additional Parameter	0~9	0	
P30_00	0x2400	Ag Work Mode	-		
P30_01	0x2402	ASR Loop Time	1~1	1	Ms
P30_02	0x2404	Ag Run	0: Stop, 1: Run		
P30_03	0x2406	Works Status	0~0	0	-

P30_04	0x2408	Ag Target Speed Display	0~0	0	Hz
P30_05	0x240A	Ag Ramp Output Speed Display	0~0	0	Hz
P30_06	0x240C	Ag Target Position Display	0~0	0	Pulse
P30_07	0x240E	Ag Target Position Frq Display	0~0	0	Pulse
P30_08	0x2410	Ag Following Error Display	0~0	0	Pulse
P31_00	0x2420	Carrier Frequency	2k,3k,4k,5k,6k,8k		Hz
P31_01	0x2422	Dead Time	2.8~5.2	3.2	us
P32_00	0x2440	VVVF Output Voltage Max	0~380	380	V
P32_01	0x2442	Acc Current Limit Multiple	0~2	1	Rated current multiple
P32_02	0x2444	Dec Current Limit Multiple	0~2	1	Rated current multiple
P32_03	0x2446	Over Current Voltage Dec	0.1~50	10	V/s
P32_04	0x2448	Over Current Voltage Recover Acc	0.1~50	5	V/s
P32_05	0x244A	Torque Raise Voltage Multiple	0~0.1	0.05	*Rated voltage
P32_06	0x224C	Torque Raise Stop Frequency Multiple	0~0.5	0.1	*base frequency
P33_00	0x2480	ACR IM KP Low	0~3	0.5	-
P33_01	0x2482	ACR IM KP High	0~3	1	-
P33_02	0x2484	ACR IT KP Low	0~3	0.5	-
P33_03	0x2486	+	0~3	1	-
P33_04	0x2488	ACR KP Switch Low Speed	0~1000	50	Hz
P33_05	0x248A	ACR KP Switch High Speed	0~1000	100	Hz
P33_06	0x248C	ACR IM_KI	0~3	0.05	-
P33_07	0x248E	ACR IM_KI Coef	0~3	0.3	-
P33_08	0x2490	ACR IT_KI	0~3	0.05	-
P33_09	0x2492	ACR IT_KI Coef	0~3	0.3	-
P33_50	0x24C0	ACR IM KP Low(High speed gear)	0~3	0.5	-
P33_51	0x24C2	ACR IM KP High(High speed gear)	0~3	1	-
P33_52	0x24C4	ACR IT KP Low(High speed gear)	0~3	0.5	-
P33_53	0x24C8	ACR IT KP High(High speed gear)	0~3	1	-

P33_54	0x24CA	ACR KP Switch Low Speed(High speed gear)	0~1000	50	-
P33_55	0x24CC	ACR KP Switch High Speed(High speed gear)	0~1000	100	-
P33_56	0x24CE	ACR IM_ KI (High speed gear)	0~3	0.05	-
P33_57	0x24D0	ACR IM_ KI Coef(High speed gear)	0~3	0.3	-
P33_58	0x24D2	ACR IT_ KI (High speed gear)	0~3	0.05	-
P33_59	0x2500	ACR IT_ KI Coef(High speed gear)	0~3	0.3	-
P34_00	0x2500	ASR KP at high speed	0~2	0.18	-
P34_01	0x2502	ASR KP at low speed	0~2	0.1	-
P34_02	0x2504	ASR Inertia coefficient	0~2	0.32	-
P34_03	0x2506	ASR KI Low Con	0~0.5	0.01	-
P34_04	0x2506	ASR KI High Con	0~0.5	0.004	-
P34_05	0x250A	ASR KI Low Acc	0~0.5	0.005	-
P34_06	0x250C	ASR KI High Acc	0~0.5	0.002	-
P34_10	0x2514	ASR PI Switch High Speed	0~1000	150	Hz
P34_50	0x2540	ASR KP at High Speed(high speed gear)	0~2	0.18	-
P34_51	0x2542	ASR KP at Low Speed(high speed gear)	0~2	0.2	-
P34_52	0x2544	ASR Inertia coefficient (high speed gear)	0~2	0.32	-
P34_53	0x2546	ASR KI Low Con(high speed gear)	0~0.5	0.01	-
P34_54	0x2548	ASR KI High Con(high speed gear)	0~0.5	0.004	-
P34_55	0x254A	ASR KI Acceleration&Deceleration at Low Speed(high speed gear)	0~0.5	0.005	-
P34_56	0x254C	ASR KI Acceleration&Deceleration at High Speed(high speed gear)	0~0.5	0.002	-
P34_59	0x2552	ASR KI Transformation at Low Speed point(high speed gear)	0~100	5	Hz
P34_60	0x2554	ASR KI Transformation at High Speed point(high speed gear)	0~1000	150	Hz
P35_00	0x2580	APR Inertia coefficient	0~0.5	0.1	-
P35_02	0x2584	APR KI at Zero Speed	0~0.5	0.01	-
P35_03	0x2586	APR KI at Low Speed	0~0.5	0.005	-

P35_04	0x2588	APR KI at High Speed	0~0.5	0.01	-
P35_05	0x258A	APR KP at Zero Speed	0~0.5	0.001	-
P35_06	0x258C	APR KP at Low Speed	0~0.5	0.01	-
P35_07	0x258E	APR KP at High Speed	0~0.5	0.001	-
P35_08	0x2590	APR Pi Switch Low Speed	0~100	5	Hz
P35_09	0x2592	APR Pi Switch High Speed	0~1000	152	Hz
P35_50	0x25D4	APR Inertia coefficient(high speed gear)	0~2	0.5	-
P35_52	0x25D6	APR KI at Zero Speed(high speed gear)	0~1	0.1	-
P35_53	0x25D8	APR KI at Low Speed(high speed gear)	0~1	0.1	-
P35_54	0x25DA	APR KI at High Speed(high speed gear)	0~1	0.05	-
P35_55	0x25DC	APR KP at Zero Speed(high speed gear)	0~2	0.5	-
P35_56	0x25DE	APR KP at Low Speed(high speed gear)	0~2	0.2	-
P35_57	0x25E0	APR KP at High Speed(high speed gear)	0~2	0.1	-
P35_58	0x25D0	APR PI switch at Low Speed Point(high speed gear)	0~100	5	-
P35_59	0x25D2	APR PI switch at High Speed Point(high speed gear)	0~1000	15	Hz
P50_00	0x2800	OP	0: External; 1: Panel; 2: Self-learning		
P50_01	0x2802	OP Power On	-		
P50_02	0x2804	Op Speed Ins	-30000~30000	100	rpm
P50_03	0x2806	OP Acc	0~1000	10	Hz/s
P50_04	0x2808	OP Dec	0~1000	0	Hz/s
P50_05	0x280A	OP Speed Ins Dir	0: Forward Direction 1: Reverse Direction		
P51_00	0x2820	Position Or Accurate Stop	0: Position Prefer 1: Homing Prefer		
P51_01	0x2822	Speed Or Torque	0: Speed Prefer; 1: Torque Prefer		
P51_02	0x2824	Accurate Stop Trigger Type	0: High Effective; 1: Pulse Effective/Power on when input change		
P52_00	0x2840	Emergency Type	0: Brake Stop, 1: Free Stop		

P52_01	0x2842	Lost DI Emergency Type	0: Brake Stop, 1: Free Stop		
P52_02	0x2844	Emergency Dec	1~1000	50	Hz/s
P52_03	0x2846	Emergency Dec Torque Limit	0.1~2.5	1.5	*Rated torque
P52_04	0x2848	None DI Power Off Delay Time	0~900000	0	ms
P52_05	0x284A	Soft Forward Limit Shift	0~2147483648.9	0	Pulse
P52_06	0x284C	Soft Reverse Limit Shift	0~2147483648.9	0	Pulse
P53_00	0x2880	Position Control Type	0: Follow, 1: Synchronize		
P53_01	0x2882	Position Feed Back Source	0: Motor Encoder, 1: Second Encoder		
P53_02	0x2884	Position Ins Type	0: 0~10V, 1: ±10V, 2: external pulse, 3: mBUS absolute type, 4: mBUS Interpolation type		
P53_03	0x2886	Position Ins Filter Time	0~100	2	ms
P53_04	0x2888	Pos Max Speed	1~30000	1000	rpm
P53_05	0x288A	Pos Min Speed	0.01~1	0.1	rpm
P53_06	0x288C	Pos Max Inertia Speed	1~100	30	rpm
P53_07	0x288E	Pos Stiff	0.00001~1	0.01	-
P53_08	0x2890	Pos Acc Stiff	0.00001~1	0	-
P53_09	0x2892	Pos Ins Gear Ration	0~10000	1	-
P53_10	0x2894	Position Ins Dir	0: Forward Direction 1: Reverse Direction		
P53_11	0x2896	Pos Acc Torque Limit	0.1~4	2	*Rated torque
P53_12	0x2898	Pos Dec Torque Limit	0.1~4	2	*Rated torque
P53_13	0x289A	Pos Inertia Zone	1~500	30	Pules
P53_14	0x289C	Pos Climb Zone	1~50	10	Pules
P53_15	0x289E	Pos Control Precision	1~100	2	Pules
P53_16	0x28A0	Mbus Target Position	0~0XFFFF FFFF	0	Pules
P53_17	0x28A2	Pos 10V max Speed	0~30000	1000	rpm
P53_19	0x28A6	Position Velocity mode Acc	0~1000	50	Hz/s

P53_20	0x28A8	Position Velocity mode Dec	0~1000	50	Hz/s
P54_00	0x2900	Accurate Stop Control Type	0: Fund Z forward homing 1: Fund Z backward homing 2: Nearby homing		
P54_01	0x2902	Accurate Stop Feed Back Source	0: Motor Encoder, 1: Second Encoder		
P54_02	0x2904	Accurate Stop Dec	0000	50	Hz/s
P54_03	0x2906	Accurate Stop Search Z-Speed	0~200	100	rpm
P54_04	0x2908	Accurate Stop Pos Max Speed	0~200	100	rpm
P54_07	0x290E	Accurate Stop Stiff	0.0001~0.1	0.001	-
P54_10	0x2914	Accurate Stop Precision	0~100	2	Pulse
P54_12	0x2918	Accurate Stop Position 1	0~999999	1000	Pulse
P54_13	0x291A	Accurate Stop Position 2	0~999999	2000	Pulse
P54_14	0x291C	Accurate Stop Position 3	0~999999	3000	Pulse
P54_15	0x291E	Accurate Stop Position 4	0~999999	4000	Pulse
P55_00	0x2980	Speed Algorithm Type	0: VVVF Control, 1: Asynchronous Motor Speed Sensor FOC Control		
P55_01	0x2982	Speed Feed Back Source	0: Motor Encoder, 1: Second Encoder		
P55_02	0x2984	Speed Ins Type	0: 0~10V, 1: $\pm 10V$ 2: External Pulse, 3: mBUS, 4: 16 gear speed		
P55_03	0x2986	Speed Zero Lock Time Delay	0: Speed closed loop, 1: Position closed loop		
P55_04	0x2988	Speed Control S-Curve Time	1~10000	1	ms
P55_05	0x298A	Speed Control Max Speed	0~30000	3000	rpm
P55_06	0x298C	Speed Control Min Speed	0~3000	0	rpm
P55_07	0x298E	Speed Control Low Speed Acc	0~1000	50	Hz/s
P55_08	0x2990	Speed Control Low Speed Dec	0~1000	50	Hz/s
P55_09	0x2992	Speed Control Adj Speed Sw Point	1~30000	1500	rpm
P55_10	0x2994	Speed Control Hi Speed Acc	0~1000	50	Hz/s
P55_11	0x2996	Speed Control Hi Speed Dec	0~1000	50	Hz/s
P55_12	0x2998	Speed Control Reach Field	1~500	10	rpm

P55_13	0x299A	Speed Control Ins Gear Ratio	0~10000	1	-
P55_14	0x299C	Speed Control Speed Ins Dir	0: Forward Direction 1: Reverse Direction		
P55_15	0x299E	Speed Control Speed Inv Disable	0~1	0	-
P55_18	0x29A4	Speed Control Speed Ins Resolution	1~1000	1	rpm
P55_19	0x29A6	Speed Control Mbus Target Speed	-30000~30000	0	rpm
P55_20	0x29A8	Gear Speed 0	-30000~30000	0	rpm
P55_21	0x29AA	Gear Speed 1	-30000~30000	0	rpm
P55_22	0x29AC	Gear Speed 2	-30000~30000	0	rpm
P55_23	0x29AE	Gear Speed 3	-30000~30000	0	rpm
P55_24	0x29B0	Gear Speed 4	-30000~30000	0	rpm
P55_25	0x29B2	Gear Speed 5	-30000~30000	0	rpm
P55_26	0x29B4	Gear Speed 6	-30000~30000	0	rpm
P55_27	0x29B6	Gear Speed 7	-30000~30000	0	rpm
P55_28	0x29B8	Gear Speed 8	-30000~30000	0	rpm
P55_29	0x29BA	Gear Speed 9	-30000~30000	0	rpm
P55_30	0x29BC	Gear Speed 10	-30000~30000	0	rpm
P55_31	0x29BE	Gear Speed 11	-30000~30000	0	rpm
P55_32	0x29C0	Gear Speed 12	-30000~30000	0	rpm
P55_33	0x29C2	Gear Speed 13	-30000~30000	0	rpm
P55_34	0x29C4	Gear Speed 14	-30000~30000	0	rpm
P55_35	0x29C6	Gear Speed 15	-30000~30000	0	rpm
P55_36	0x29C8	Zero Speed no Output Range	0~999	50	rpm
P56_00	0x2A00	Torque Ins Type	0: 0~10V, 1:±10V, 3 mBUS, 4:16 gear		
P56_01	0x2A02	Max Torque	0~3	2	*Rated torque
P56_02	0x2A04	Torque Acc	0.01~10	1	*Rated torque
P56_03	0x2A06	Torque Dec	0.01~10	1	*Rated torque
P56_04	0x2A08	Torque Ins Dir	0: Forward Direction 1: Reverse Direction		

P56_05	0x2A0A	Torque Fwd Max Speed	0~30000	1500	rpm
P56_06	0x2A0C	Torque Rev Max Speed	0~30000	1500	rpm
P56_07	0x2A0E	Torque Ctl Fwd Attenuation	0~10	0.1	* Torque /Hz
P56_08	0x2A10	Torque Ctl Rev Attenuation	0~10	0.1	*Torque /Hz
P56_09	0x2A12	Torque Attenuation Step Speed	0~10	10	rpm
P56_10	0x2A14	Mbus Target Torque	-3~3	0	*Rated torque
P57_00	0x2A40	Jog Max Speed	0~1000	100	rpm
P57_01	0x2A42	Jog Acceleration	0~100	30	Hz/s
P57_02	0x2A44	Jog Dec	0~100	30	Hz/s
P57_03	0x2A46	Jog Dir	0: Forward Direction 1: Reverse Direction		
P58_00	0x2A60	Swing Angle	0~360	20	degree
P58_01	0x2A62	Swing Speed	0~30	30	rpm
P58_02	0x2A64	Swing Acceleration	0~50	30	Hz/s
P59_00	0x2A80	Start Identify	-		
P59_01	0x2A82	Identify Mac Speed	0~300	100	rpm
P60_00	0x2AA0	Rapier Enable	0~1	0	-
P60_01	0x2AA2	Rapier Speed Instruction Source	0: 3 rd Gear,1: 3 rd Gear(Enable),2:10V Analog Quantity,3: 4 th Gear,4: Pulse Quantity,5: Speed of 16 th Gear		
P60_02	0x2AA4	Rapier Speed and Direction	0~1	0	-
P60_03	0x2AA6	Rapier Deceleration	0~1000	100	Hz/s
P60_05	0x2AAA	Rotational Speed of Rapier 1 st Gear	0~8000	100	rpm
P60_06	0x2AAC	Rotational Speed of Rapier 2 nd Gear	0~8000	600	rpm
P60_07	0x2AAE	Rotational Speed of Rapier 3 rd Gear	0~8000	800	rpm
P60_08	0x2AB0	Rotational Speed of Rapier 4 th Gear	0~8000	1000	rpm

P60_09	0x2AB2	Torque of Rapier 1 st Gear	0.1~3	2	Rated Torque Multiple
P60_10	0x2AB4	Torque of Rapier 2 nd Gear	0.1~3	2	Rated Torque Multiple
P60_11	0x2AB6	Torque of Rapier 3 rd Gear	0.1~3	2	Rated Torque Multiple
P60_12	0x2AB8	Torque of Rapier 4 th Gear	0.1~3	2	Rated Torque Multiple
P60_13	0x2ABA	Acceleration for Torque of Rapier 1 st Gear	0.01~90	50	Rated Torque Multiple /s
P60_14	0x2ABC	Acceleration for Torque of Rapier 2 nd Gear	0.01~90	50	Rated Torque Multiple /s
P60_15	0x2ABE	Acceleration for Torque of Rapier 3 rd Gear	0.01~90	50	Rated Torque Multiple /s
P60_16	0x2AC0	Acceleration for Torque of Rapier 4 th Gear	0.01~90	50	Rated Torque Multiple /s
P60_17	0x2AC2	Speed and Torque Switching Time of Rapier	0~5000	800	ms
P60_20	0x3AD0	Auto Max Rotational Speed of Industrial Fabric Dyeing Machine	-10000~10000	1000	rpm

P60_22	0x3AD4	Man Rotational Speed of Industrial Fabric Dyeing Machine	-10000~10000	1000	rpm
P60_23	0x3AD6	Man Acceleration of Industrial Fabric Dyeing Machine	0~100	30	Hz/s
P60_24	0x3AD8	Auto Deceleration of Industrial Fabric Dyeing Machine	0~100	30	Hz/s
P60_25	0x3ADA	Dehydration Speed of Industrial Fabric Dyeing Machine	-10000~10000	1500	rpm
P60_26	0x3ADC	Dehydration Acceleration of Industrial Fabric Dyeing Machine	0~100	30	Hz/s
P60_27	0x3ADE	Dehydration Deceleration of Industrial Fabric Dyeing Machine	0~100	30	Hz/s
P60_28	0x3AE0	Sampling Rotational Speed of Industrial Fabric Dyeing Machine	-10000~10000	500	rpm
P60_29	0x3AE2	Sampling Acceleration of Industrial Fabric Dyeing Machine	0~100	30	Hz/s
P60_30	0x3AE4	Sampling Deceleration of Industrial Fabric Dyeing Machine	0~100	30	Hz/s
P60_31	0x3AE6	Sampling Power-off Time of Industrial Fabric Dyeing Machine	0~1000	100	s
P70_00 ~ P70_04	0x3800 ~ 0x3808	Attachment Function 1 ~ Attachment Function 5	-99999 ~ 99999	0	-
P70_05 ~ P70_09	0x380A ~ 0x3812	Attachment Function 6 ~ Attachment Function 10	-9.9999 ~ 9.9999	0	-
P70_10 ~ P70_14	0x3814 ~ 0x381C	Attachment Function 11 ~ Attachment Function 15	-99.999 ~ 99.999	0	-
P70_15 ~ P70_19	0x381E ~ 0x3826	Attachment Function 16 ~ Attachment Function 20	-999.99 ~ 999.99	0	-

P70_20	0x3828	Attachment Function21	-9999.9	0	-
~	~	~	~		
P70_24	0x3830	Attachment Function 25	9999.9		
P70_25	0x3832	Attachment Function26	-99999	0	-
~	~	~	~		
P70_34	0x3844	Attachment Function 35	99999		
P88_00	0x3E00	Soft Oscilloscope Sampling Time Interval	1~1000	1	-
P88_01	0x3E02	Trigger Type of Soft Oscilloscope	0~2	0	-
P88_02	0x3E04	Trigger Pulse Number of Soft Oscilloscope	0~10000	0	-
P88_03	0x3E06	Soft Oscilloscope Sampling Signal Type	0~100	0	-
P89_00	0x3F00	Data Display Settings 0	1:Rotational Speed(F32),2:Slope Speed(F32),3:Electricity (F32),4:Torque(F32),5:Absolute Position of Motor(I32),6:Position Error(I32),7:Alarm(I32),8:Motor Encoder Meter Value(I32),9:External Pulse Meter Value(I32),11:Rotational Speed(I32),12:Slope Rotational Speed(I32),13:Electricity(I32), 14:Torque(I32).		
P89_01	0x3F02	Data Display Rate 0	0.001~999.999	1	-
P89_02	0x3F04	Data Display Settings 1	As Same As P89_00		
P89_03	0x3F06	Data Display Rate 1	0.001~999.999	1	-
P89_04	0x3F08	Data Display Settings 2	As Same As P89_00		
P89_05	0x3F0A	Data Display Rate 2	0.001~999.999	1	-

P89_06	0x3F0C	Data Display Settings 3	As Same As P89_00		
P89_07	0x3F0E	Data Display Rate 3	0.001~999.999	1	-
P89_08	0x3F10	Data Display Settings 4	As Same As P89_00		
P89_09	0x3F12	Data Display Rate 4	0.001~999.999	1	-
P89_10	0x3F14	Data Display Settings 5	As Same As P89_00		
P89_11	0x3F16	Data Display Rate 5	0.001~999.999	1	-
P89_12	0x3F18	Data Display Settings 6	As Same As P89_00		
P89_13	0x3F1A	Data Display Rate 6	0.001~999.999	1	-
P89_14	0x3F1C	Data Display Settings 7	As Same As P89_00		
P89_15	0x3F1E	Data Display Rate 7	0.001~999.999	1	-
P89_16	0x3F20	Data Display Settings 8	As Same As P89_00		
P89_17	0x3F22	Data Display Rate 8	0.001~999.999	1	-
P89_18	0x3F24	Data Display Settings 9	As Same As P89_00		
P89_19	0x3F26	Data Display Rate 9	0.001~999.999	1	-
P89_60	0x3F40	Data Display 0	Vlu=P89_00(Definition)*P89_01		
P89_61	0x3F42	Data Display 1	Vlu=P89_02(Definition)*P89_03		
P89_62	0x3F44	Data Display 2	Vlu=P89_04(Definition)*P89_05		
P89_63	0x3F46	Data Display 3	Vlu=P89_06(Definition)*P89_07		
P89_64	0x3F48	Data Display 4	Vlu=P89_08(Definition)*P89_09		
P89_65	0x3F4A	Data Display 5	Vlu=P89_10(Definition)*P89_11		
P89_66	0x3F4C	Data Display 6	Vlu=P89_12(Definition)*P89_13		
P89_67	0x3F4E	Data Display 7	Vlu=P89_14(Definition)*P89_15		
P89_68	0x3F50	Data Display 8	Vlu=P89_16(Definition)*P89_17		
P89_69	0x3F52	Data Display 9	Vlu=P89_18(Definition)*P89_19		

			19		
P90_00	0x4000	Error Status	0~0	0	-
P90_01	0x4002	Clear Warning	Clear after writer 1, and auto return to 0.		
P90_02	0x4004	Under Voltage Mask	0:Error,power off 1:Error,power on >=3: No Error;Limit Torque%		
P90_03	0x4006	Motor Over Temp Mask	0:Error,power off 1:Error,power on >=3: No Error;Limit Torque%		
P90_04	0x4008	Motor Overload Mask			
P90_05	0x400A	IGBT Over Temp Mask			
P90_06	0x400C	Speed Drop Mask	0:Error,Power off 1:Error,Power on		
P91_00	0x4100	Warn 0 Number	Warning number when warning occur		
P91_01	0x4102	Warn 0 Warn ID 0	Record the warning type in turn when warning, up to 8 types.		
P91_02	0x4104	Warn 0 Warn ID 1			
P91_03	0x4106	Warn 0 Warn ID 2			
P91_04	0x4108	Warn 0 Warn ID 3			
P91_05	0x410A	Warn 0 Warn ID 4			
P91_06	0x410C	Warn 0 Warn ID 5			
P91_07	0x410E	Warn 0 Warn ID 6			
P91_08	0x4110	Warn 0 Warn ID 7			
P91_09	0x4112	Warn 0 Current	Current When Warning	A	
P91_10	0x4114	Warn 0 Udc	Udc Voltage When Warning	V	
P91_11	0x4116	Warn 0 Torque	Torque When Warning	Nm	
P91_12	0x4118	Warn 0 Speed	Speed When Warning	rpm	
P91_13	0x411A	Warn 0 Status	Driver Status When Warning		
P91_14	0x411C	Warn 0 Work Mode	Work Loop Status When Warning		

Chapter 7 Safety Precautions

Our Products is equipped with complete protection functions to provide efficient protection while utilizing its performance sufficiently. Some failure instructions may be displayed during operation. Compare the instructions with the following table and analyze, decide the causes and solve failures.

For damages on units or questions that can't be resolved, please contact with local distributors/agents, service centers or manufacturer for solutions.

7.1 Failure and Solutions

Failure code	Failure description	Potential causes	Solutions
Err-00	Over voltage protection	Deceleration time is too short	Lengthen deceleration time
		Brake resistor is damage or not reasonable	Choose appropriate energy braking components
Err-01	Under voltage protection	The power voltage is lower than the minimum operating voltage of equipment	Check input power supply
Err-02	Over current protection when acceleration operation	Low grid voltage	Check input power supply
		Power level of drive is small	Replace with drive with proper model
		Acceleration time is too Short	Lengthen acceleration time
		Improper setting of system parameters	Set system parameters properly
		output side of the motor was short circuited	Check whether the motor the output connection are short circuited
Err-03	Over current protection when deceleration operation	Low grid voltage	Check input power supply
		Brake resistor is not reasonable	Choose appropriate energy braking components
		Deceleration time is too short	Lengthen deceleration time
		Power level of drive is small	Replace with drive with proper model
		Improper setting of system parameters	Set system parameters properly
		output side of the motor was short circuited	Check whether the motor the output connection are short circuited

Err-04	IGBT Overheated	Ambient over-temperature	Lower the ambient temperature and strengthen ventilation and radiation
Err-05	Motor encoder failure	Encoder or motor cable connection is incorrect	Change the encoder cable connection and reconnect
		system parametersE04 is incorrect	Check system parameters P14_01
Err-06	Motor overheated	The motor temperature signal reaches the alarm setting value	Strengthen ventilation and radiation
Err-07	Current detection abnormal	Current detection circuit breakdown	Contact with technician
Err-08	Environment overheated	Environment temperature is too high	Setting parameter P10_15 to alter the error point
Err-09	Motor overload protection	Motor phase sequence is incorrect	Exchange output terminals U and V
		Keep overloading for along period of time	Shorten the overloading time
		Motor rotation is blocked or load mutation occurs	Prevent the motor rotation from blocking and reduce the load mutation
Err-13	New parameter alarm	Appear after the new transmission program	Turn off the power and turn on again
Err-15	The 2 nd encoder fault	Encoder cable breakdown or connect incorrect	Check the connection of cable
Err-16	IO board self-detection fault	Error when execute the IO board self-detection	
Err-17	IO board fault	GSIO interface loosening	Check the connection of IO board
		The type of IO board is incorrect	Check the parameter P20_04
Err-18	Dual Speed Relay Shift State Error	Dual Speed Relay Shift State missing	Check Dual Speed Relay
Err-20	Encoder Z Error	Encoder Z Phase Lost	Change Encoder
Err-21	Encoder Parameter Setting Error	Encoder Parameter Setting Abnormal	Check P14_01

Err-22	Recovery Parameter Error when Power on	Inner EEPROM Error	Communicate with FAE
Err-24	Precision of Homing Error	Position of Homing doesn't reach at setting precise	Increase P54_10 parameter appropriately
Err-26	Motor torque warning	Motor torque output exceeding limit	
Err-27	Speed Stall Alarm	Load Torque too Large	

7.2 Analysis on Common Malfunction

7.2.1 No indication after the driver has been connected to the power

Cause: on indication on the manipulator after the driver has been connected to the power supply. Turn down all the attachment first, and only keep the R/S/T three-phase into line.

Reasons and countermeasures:

- 1.Charging indicator light is not bright, measured with a multimeter R/S/T into the line voltage, normal power supply: $300\text{ V} < \text{power supply voltage} < 440\text{ V}$;
- 2.If the power supply is normal, the rectifier bridge or charging resistance is damaged, return to factory maintenance or professional maintenance;
- 3.Charging indicator: rectifier bridge is normal, normal charging resistance, switch power supply damage or fuse burned down, return to factory maintenance;

7.2.2 Leakage protection switch trips

Cause: the leakage protection switch trips after the servo spindle start-up.

Reasons and countermeasures:

- 1.A plain leakage protection switch with a leakage protection value of 200mA is recommended; otherwise candle the leakage protection switch;
- 2.Use the specified leakage protection switch dedicated to servo(or transducer) with a leakage protection value of 30mA;
- 3.Add an isolating transformer between the plain leakage protection switch and servo driver.

7.2.3 Symptom for encoder failure

Cause: 1.Err - 05 encoder fault alarm

- 2.Spindle rotation at low speed, speed command control
- 3.Appear coasters phenomenon
- 4.Running speed uneven, there are obvious impact type mechanical vibration
- 5.no-load monitoring current A_0 , found that current significantly larger, rated worth when no-load current of about 15%
- 6.To monitor torque when there is no load torque big or the full torque has been reached
- 7.Often Err - 02, Err - 03, Err - 09 alarm

Reasons and Countermeasures:

- 1.Check whether the CN2 terminal and motor encoder is connected encoder line;
- 2.If already properly connected, can be manually rotating machine, and view the

monitoring parameter P, if the motor encoder is 1024 line installation, is a revolution of the motor shaft, 4096 pulse parameter P should change;

3.If no change parameter P, please carefully check the lines to the encoder or replace the encoder. Controller is measured with a multimeter CN2 port encoder on the power supply, if no voltage,drive internal power supply is damaged, need to change the drive;

4.If attachment is correct, the power supply is normal, the encoder may damage, need to change the motor encoder;

5.If parameter P change, but change pulse number for each lap 10000pulses, the actual line number should be 2500 line motor encoder,please contrast encoder on the motor nameplate value, modify the P14_01 parameters.

7.2.4 Frequent Alarms of Er -01

Cause: 1.unstable or failed power supply, please use the multimeter to measure the controller of R/S/T port, to determine whether the power fluctuation is bigger;

2.Large equipment start may cause instantaneous under voltage, this kind of situation can't use multimeter test;

Reasons and Countermeasures:

1.Add a regulated power supply where the power supply is unstable.

2.Adjust E46 settings,close under-voltage protection.

7.2.5 Spindle can not be turned or rotate slowly without control

Reasons and countermeasures:

1.The spindle speed is not controlled, may cause is the motor phase sequence errors.

2.Perform OP = 2 (self-study) operation, after the success of the self learning, and change the OP to 0 (outside the terminal control);

3.Spindle don't work, need to check whether the controller receives the correct control instruction;

Example: CNC executes instructions M03 S500, requiring motor at 500 RPM is rotating.

Executes the instruction, the system should be connected to the controller I0 input terminal, whether by monitoring parameter d the vertical bar on the right side of the pop-up, I0 can be confirmed to be correct access:

1) If no pop-up, explain the signal is not properly access, check whether the I0 CN1 port terminal is connected correctly, or whether the 24V power supply access, or SEL terminals are connected correctly.

2) If other vertical bar pop-up, the 24V power supply and SEL terminal correct, I0 connection to other ports.

Executes the instruction, the system may by pulse, 0 ~ 10V analog or 10V analog to represent the speed command, the following instructions:

1) If using pulse wave velocity, setting P55_02 = 2, set up the P22_01,depending on the type of pulse by monitoring parameter F(external pulse frequency), determine the correct pulse input;

2) If use 0 ~ ± 10V analog, set P55_02= 0, by monitoring parametersA1, determine whether or not the correct input;

3) If use ± 10V analog, set P55_02 = 1, by monitoring parameters A1, determine

whether or not the correct input.

If above countermeasures are invalid, please contact technical support.

7.2.6 The spindle speed is inaccurately

Reasons and countermeasures:

Pulse speed control:

- 1) Confirm whether encoder line number parameters in CNC system with P54_12 parameters matching;
- 2) Whether the spindle drive ratio;

Analog speed control:

- 1) Confirm whether the highest spindle speed in CNC system with P55_05 parameters matching;
- 2) Analog voltage whether receive accurate, and can be through of monitoring parameter A1 ;
- 3) If analog into is proportional to the deviation, such as CNC setting of 1000 RPM, motor speed is 980 RPM, if CNC setting of 2000 RPM, motor speed is 1960 RPM, can be appropriately increase F00;
- 4) If analog deviation as a fixed value, such as CNC setting of 1000RPM, motor speed is 980 RPM, setting of 2000 RPM, motor speed is 1980 RPM, can adjust the F4X group parameter modification;

If above countermeasures are invalid, please contact technical support.

7.2.7 Inaccurate positioning of spindle

Reasons and countermeasures:

1. For the first use or replacement of spindle parts. Readjust the positioning angle. Adjust parameter: P54_12
2. After used for a certain period .check for any loosen synchronous belt and that of spindle motor and for any loosen coder of spindle motor.
3. Occasional inaccurate positioning during the operation. Please contact the manufacture if the followings are confirmed: Coder is connected firmly and the shield is grounded well. Logic of control sequence for positioning is in good order. It remains inaccurate positioning when handling it manually by means of MDI If above countermeasures are invalid, please contact technical support.

Description of safety marks:

Danger: The misuse may cause fire, severe injury, even death.

Note: The misuse may cause medium or minor injury and equipment damage.

◆ Installation

 Note
<ul style="list-style-type: none">★ If the drive is found to be damaged or lack parts, the drive cannot be installed. Otherwise, accident may be caused.★ The drive shall be mounted on the fire retardant surface, such as metal, and kept far away from the inflammable and heat source.★ Keep the drilling scraps from falling into the inside of the drive during the installation; otherwise, drive failure may be caused.★ When the drive is installed inside the cabinet, the electricity control cabinet shall be equipped with fan and ventilation port. And ducts for radiation shall be constructed in the cabinet.

◆ Wiring

 Danger
<ul style="list-style-type: none">★ Before wiring, confirm that the power supply is disconnected. Otherwise, there exists the risk of electric shock or fire.★ The wiring must be conducted by qualified electricians. Otherwise, there exists the risk of electric shock or drive damage.★ The drive input and output cables with proper sectional area shall be selected according to the drive power.★ Please confirm that the power supply phases, rated voltage are consistent with that of the nameplate, otherwise, the drive may be damaged.★ Do not perform dielectric strength test on the drive, otherwise, the drive may be damaged.★ The grounding terminal E must be reliably grounded, otherwise, the drive enclosure may become live.★ The three-phase power supply cannot connect to output terminals U, V and W, otherwise, the drive will be damaged.★ The wires of the main circuit terminals and the wires of the control circuit terminals shall be laid separately or in a square-crossing mode, otherwise, the control signal may be interfered.

◆ **Operation**



- ★ In the power-on state, please do not touch the drive terminals; otherwise, there exists the risk of electric shock.
- ★ The failure and alarm signal can only be reset after the running command has been cut off. Otherwise, personal injury may be caused.
- ★ Do not start or shut down the drive by switching on or off the power supply, otherwise, the drive may be damaged.
- ★ When it is used on lifting equipment, mechanical contracting brake shall also be equipped.
- ★ Before operation, please confirm if the motor and equipment are in the allowable use range, otherwise, the equipment may be damaged.
- ★ The heat sink and the braking resistor have high temperature. Please do not touch such device; otherwise, you may be burnt.
- ★ Please do not change the drive parameter randomly. Most of the factory set parameters of the drive can meet the operating requirement, and the user only needs to set some necessary parameters. Any random change of the parameter may cause the damage of the mechanical equipment.

◆ **Maintenance, Inspection**

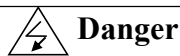

- ★ In the power-on state, please do not touch the drive terminals; otherwise, there exists the risk of electric shock.
- ★ If cover is to be removed, the power supply must be disconnected first.
- ★ Wait for at least 10 minutes after power off or confirm that the CHARGE LED is off before maintenance and inspection to prevent the harm caused by the residual voltage of the main circuit electrolytic capacitor to persons.
- ★ The components shall be maintained, inspected or replaced by qualified electricians.
- ★ The circuit boards have large scale CMOS IC. Please do not touch the board to avoid the circuit board damage caused by electric static.
- ★ It is forbidden to modify the drive without authorization; otherwise, personal injury may be caused.

Chapter 8 Spindle Servo Motor

8.1 Introduction of Spindle Servo Motor

SZGH series spindle servo motor is three-phase AC asynchronous servo motor, it's matching the asynchronous servo drives with excellent dynamic characteristic and wide speed range. Placing the temperature sensor in the three-phase winding motor, using for motor thermal protection. According to customer needs, using optical encoder or rotary transformer as feedback element to detect the motor's position and speed.

SZGH Series AC asynchronous spindle servo motor matched with our servo drive device. Used in machine tools , robot , petroleum,machinery,woodworking machinery,textile , printing,metallurgy,artillery, radar and automatic control equipment.

8.2 Model Description of Spindle Servo Motor

SZGH 10 - 2 - 35 - 5.5/7.5 - 4 - 1500

Brand	Seat No.	Long No.	Rated Torque	Power		Poles	Rated Speed
SZGH	10	2	35Nm	Rated	5.5kW	4	1500RPM
				Overload	7.5kW		

8.3 Series

Model of AC Spindle Servo Motor	Rated Power (kW)	Rated Torque (Nm)	Rated Current (A)	Rated Speed (rpm)	Max Speed (rpm)	Rotor inertia (kg.m ²)	Weight (KG)
SZGH08-3-9.5-1.5/2.2-4-1500	1.5	9.5	3.7	1500	8000	0.0058	25
SZGH08-4-14-2.2/3.7-4-1500	2.2	14	6	1500	8000	0.0085	30
SZGH09-2-24-3.7/5.5-4-1500	3.7	24	9.5	1500	8000	0.0136	50
SZGH10-2-35-5.5/7.5-4-1500	5.5	35	13	1500	8000	0.0146	57
SZGH10-3-48-7.5/11-4-1500	7.5	48	17	1500	8000	0.0264	75
SZGH10-4-71-11/15-4-1500	11	71	23.5	1500	8000	0.0375	93
SZGH13-2-95-15/18.5-4-1500	15	95	31	1500	8000	0.0650	114
SZGH13-3-117-18.5/22-4-1500	18.5	117	38	1500	8000	0.0780	125
SZGH13-4-140-22/30-4-1500	22	140	45	1500	8000	0.0910	138
SZGH16-1-191-30/37-4-1500	30	191	60	1500	6000	0.1740	232
SZGH16-2-235-37/45-4-1500	37	235	75	1500	6000	0.2150	270
SZGH16-3-286-45/55-4-1500	45	286	90	1500	6000	0.2640	300
SZGH16-4-350-55/75-4-1500	55	350	110	1500	6000	0.3250	350
SZGH18-1-478-75/90-4-1500	75	478	148	1500	4500	0.7440	436
SZGH18-2-573-90/110-4-1500	90	573	176	1500	4500	0.925	500
SZGH18-3-700-110/132-4-1500	110	700	210	1500	4500	1.128	500
SZGH22-1-840-132/160-4-1500	132	840	255	1500	4000	2.409	810

8.4 Specification of Spindle Servo Motor

Technical Specification	Description
Type	3 Phase AC Asynchronous Spindle Servo Motor
Rated Voltage	3Phase AC 220V/380V
Rated Power	1.5~315kW
Poles	2 Poles / 4 Poles
Rated Speed	1500/2000/3000 RPM
Encoder	Photoelectric Encoder/Rotary Encoder
Mounting	Floor Mounting/Flange Mounting
Ingress Protection	IP55
Insulation Class	F
Vibration Class	R
Coolant	Air Force Coolant
Operating of Environmental Condition	Temperature: -20℃ ~ +40℃ Humidity: 90%RH (No dewing)
Altitude	≤1000 meters

8.5 Using Tips

Note: The motor should be stored in dry and clean place, should avoid the impact

8.5.1 Installation

Checking the motor structure, protection degree, plate information is consistent with the conditions of use before installation.

A: When installation the motor shaft, should ensure that no liquid (water, coolant, etc.) from the top bearing room into internal motor. It will cause damage.

B: The motor installed prohibited from the shaft percussion or pressure, in order to avoid damage the bearing and optical encoder, etc.

C: The motor should be installed in the ventilation environment.

D: The motor installed in the vertical axis of the flange, the coaxial tolerance, with motor rotating parts, external vibration source of existence will increase the vibration of the motor. Improve the quality of the motor installed, will effectively play motor little vibration advantage.

E: With the motor rotating parts should with the motor rotor dynamic balance.

F: Install or remove with the motor rotation components (such as: coupling, flange, pulley, gear box) should use the right tools, forbid strike.

G: Provided standard motor has been for half keys dynamic balance.

H: Check out whether there is friction between the motor's stator and rotor before the motor is running.

I: The motor installation should be strengthened and coaxial. Avoid the vibration and damage.

J: With the motor rotation components should be adjusted appropriate.

K: Couldn't exceed the maximum speed of the motor nameplate marked.

Note: The improper installation and operating will affect the motor's performance and service life

8.5.2 Wiring

3.1: Each of the motor's terminal boxes comes with a wiring diagram, please check wiring diagram carefully.

3.2: Wiring of the motor's thermal protection and cooling fan power cord in the same terminals, carefully check the wiring diagram, avoid wrong connections, otherwise it will damage the motor's windings and cooling fan.

3.3: the cooling fan power supply voltage might be different according to the requirements of customers, checking the wiring diagram carefully. Avoided errors voltage, otherwise it will damage the cooling fan.

3.4: Prohibit put the cooling fan's power in parallel with the motor's power, otherwise it will damage the motor and cooling fan.

3.5: In order to make the motor get best cooling effect, cooling fan wind direction should be adjusted to the direction of the shaft end.

8.5.3 Repair and Maintenance

4.1: All maintenance must be under the manufacturer or its designated agency's guidance, otherwise the customer should take responsibility of the damage.

4.2: Running 15,000 hours or using three years need to replace the bearing, the bearing should be ordered to the manufacturer, so that the bearing's accuracy and seal special requirements can be ensured.

5: The service and commitment

Our products are free warranty for 12 months.

Customers comply with the conditions of storage and Operating motor rules, our products due to bad manufacture caused damaged or working abnormal from the date of delivery within twelve months .We free of charge to repair or replace the products for customer.

But the following condition exception:

A: The fault caused by incorrect Operating or inobservance the conditions of use.

B: Disassemble the motor non-installation site, influenced the motor's performance, will lose the right of warranty.

8.6 Motor Model Size

B3 anchor installation size

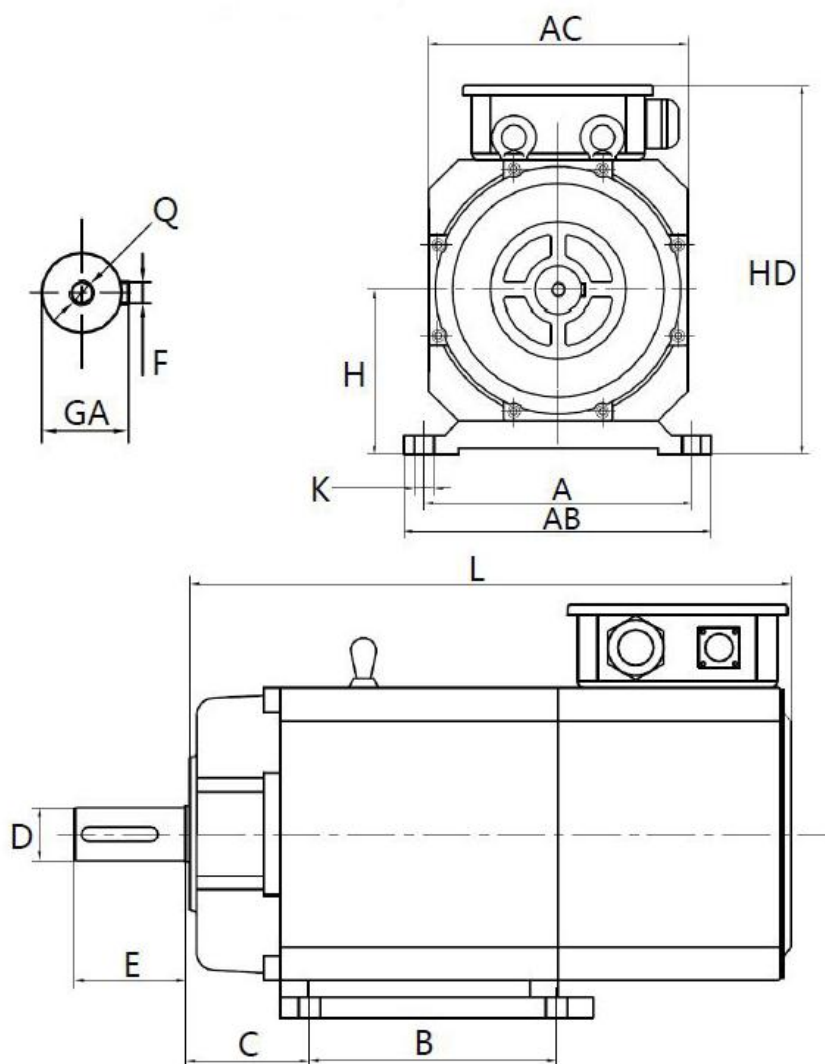

motor model	GA	Q	F	D	E	C	B	L	K	H	A	AB	AC	HD
SZGH08-4	31	M6*20	8	28	60	63	140	340	12	100	160	190	150	230
SZGH09-2	31	M6*20	8	28	60	70	140	410	12	112	190	220	180	262
SZGH10-2	41	M12*25	10	38	80	89	140	410	12	132	216	248	210	305
SZGH10-3	41	M12*25	10	38	80	89	178	450	12	132	216	248	210	305
SZGH10-4	41	M12*25	10	38	80	89	178	500	12	132	216	248	210	305
SZGH13-2	51.5	M16*30	14	48	110	108	150	520	15	160	279	319	265	360
SZGH13-3	51.5	M16*30	14	48	110	108	190	560	15	160	279	319	265	360
SZGH13-4	51.5	M16*30	14	48	110	108	230	600	15	160	279	319	265	360
SZGH16-1	64	M20*40	18	60	140	133	175	600	19	200	318	370	320	460

B5 flange mounting Size

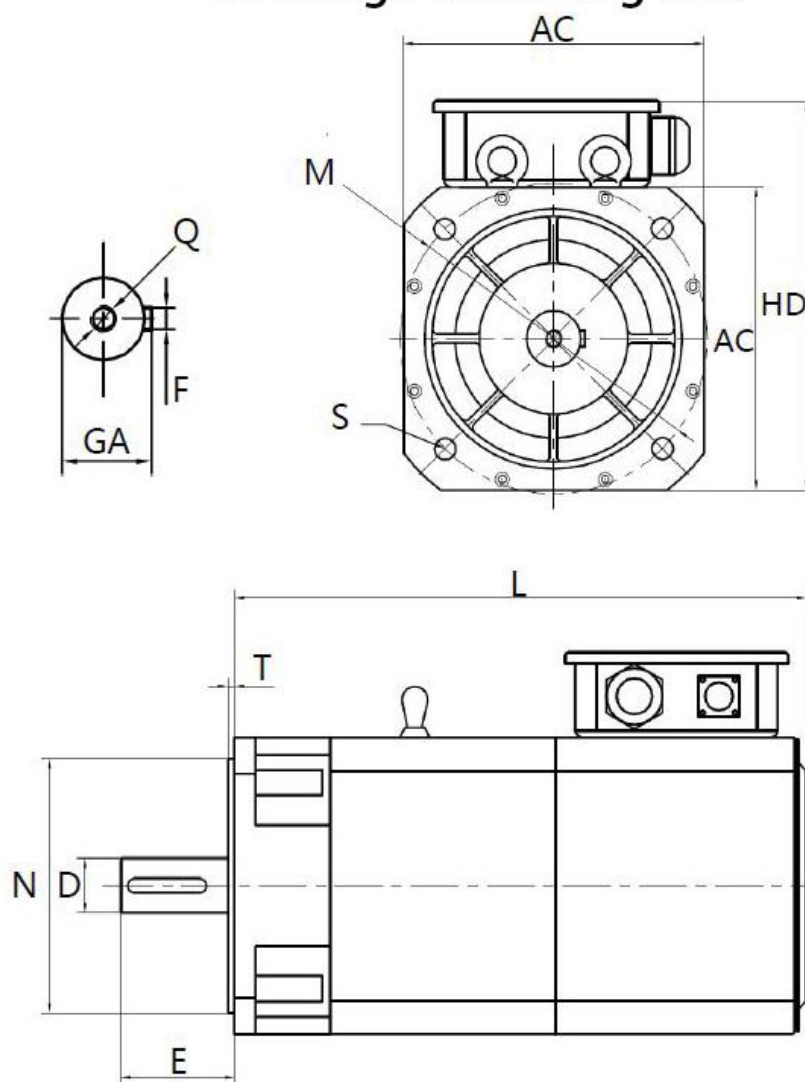

motor model	GA	Q	F	D	E	L	AC	HD	N	T	M	S	AC
SZGH08-4	31	M6*20	8	28	60	340	150	230	130	5	165	12	150
SZGH09-2	31	M6*20	8	28	60	410	180	262	150	5	185	12	180
SZGH10-2	41	M12*25	10	38	80	410	210	305	180	5	215	15	210
SZGH10-3	41	M12*25	10	38	80	450	210	305	180	5	215	15	210
SZGH10-4	41	M12*25	10	38	80	500	210	305	180	5	215	15	210
SZGH13-2	51.5	M16*30	14	48	110	520	265	360	230	5	265	15	265
SZGH13-3	51.5	M16*30	14	48	110	560	265	360	230	5	265	15	265
SZGH13-4	51.5	M16*30	14	48	110	600	265	360	230	5	265	15	265
SZGH16-1	64	M20*40	18	60	140	600	320	460	300	5	350	19	320

8.7 Dimension

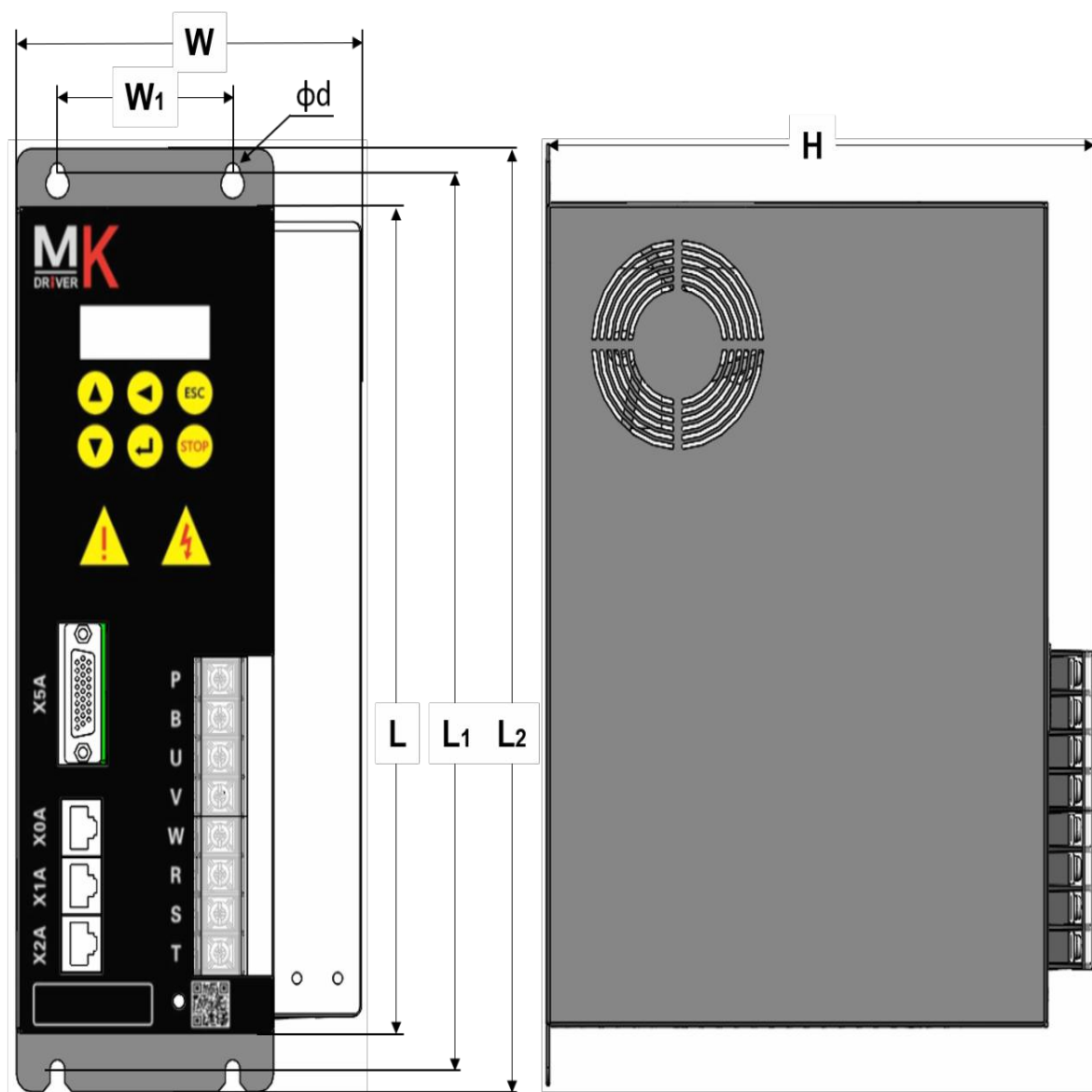

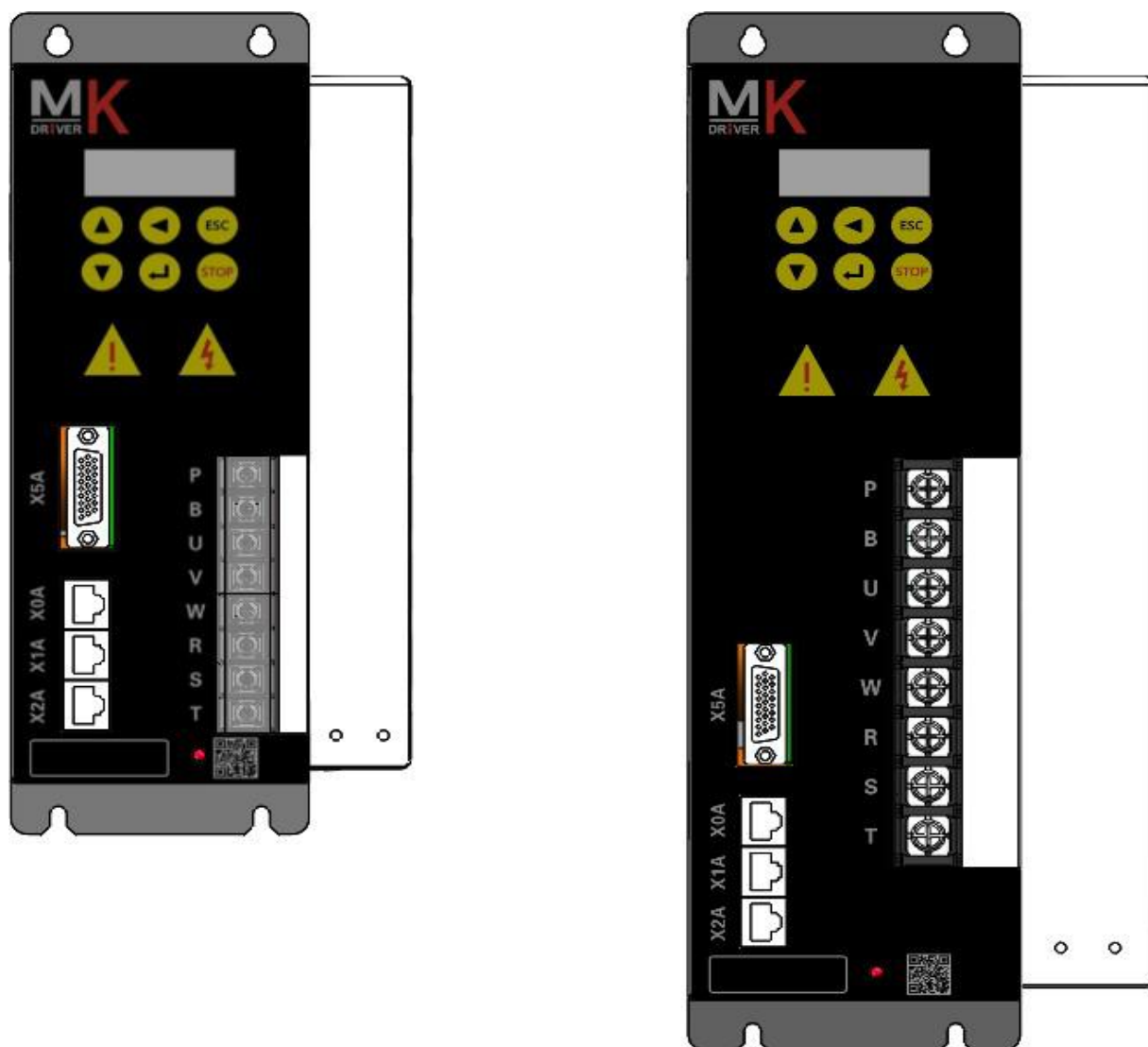

Product outline and mounting dimension

Drive Model	Outline and mounting dimension (mm)						
	Φd	L	L1	L2	W	W1	H
SZGH-S4T1P5	6.50	232	252	265	120	60	190
SZGH-S4T2P2							
SZGH-S4T3P7							
SZGH-S4T5P5							
SZGH-S4T7P5	6.5	302	322	335	140	60	200
SZGH-S4T011							
SZGH-S4T013							
SZGH-S4T015							

Note: These are standard dimension, maybe different dimension as different asks, please confirm with us.

Note: Our company has the final interpretation rights of this information.

Appendix: Wiring Diagram

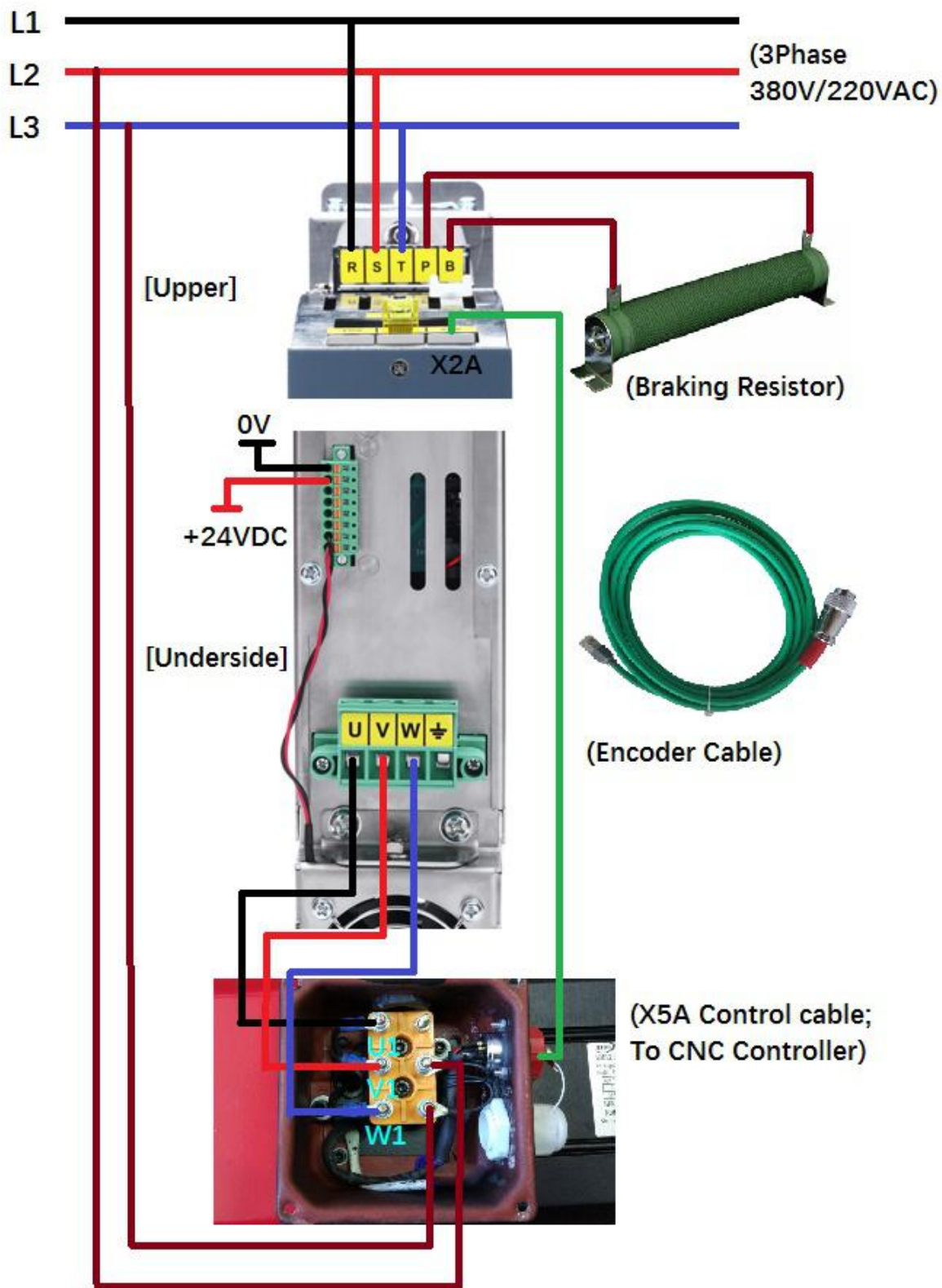

Note: Please confirm voltage of spindle system (380V/220V)