



AC SERVO DRIVES JUNMA SERIES

SJME SERVOMOTORS
SJDE SERVOPACK



CONNECT & GO

FAST & EASY SETUP

Settings are easy to make, so setup time is reduced.

1 Unpacking

Remove the SERVOPACK from the box.

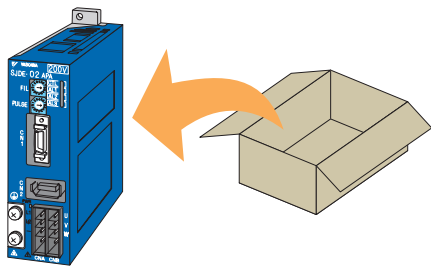

2 Installation and wiring

Connect the cables for the power supply, signal lines, and a motor.

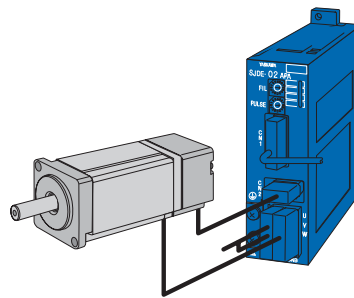

3 Reference pulse setting

Select the reference pulse switch for your controller. No parameter settings and gain adjustments are needed.

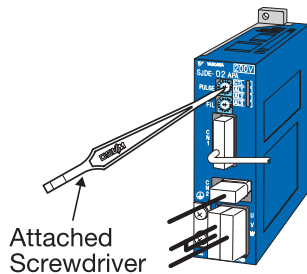

4 Setup completion

The motor is ready to run with the reference from the controller. The required torque is possible even at a high-speed rotation of 4500 min⁻¹.

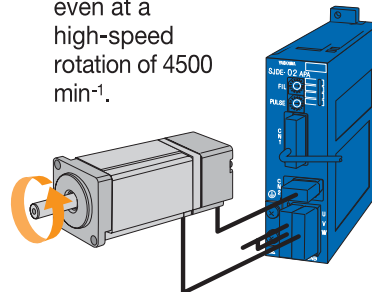

NEW CONCEPT SERVO JUNMA

With Yaskawa's world-leading servo drive technology, we are proud to introduce the Junma series for a wide range of applications.

Following our policy to make user-friendly products, the Junma series is different from conventional models, because no more parameter settings and no more servo adjustments are required; therefore, the setup and test runs are greatly reduced. Also, the Junma series has the standard servo characteristics such as high response, high speed, high torque, and high accuracy.

Try Yaskawa's Junma series to improve your system so that it better suits your needs.



SERVOMOTORS



■ Ratings and Specifications

Voltage		200 VAC				Description
Servomotor Model: SJME-□□A	01	02	04	08		
Applicable SERVOPACK	SJDE-□□A	01	02	04	08	-
Rated Output*1	W	100	200	400	750	Motor output at the rated operating point
Rated Torque*1,*2	Nm	0.318	0.637	1.27	2.39	Torque at the rated operating point
Instantaneous Peak Torque*1	Nm	0.955	1.91	3.82	7.16	Maximum instantaneous torque of the motor
Rated Current*1	Arms	0.84	1.1	2.0	3.7	Current flowing to the motor at the rated operating point
Instantaneous Max. Current*1	Arms	2.5	3.3	6.0	11.1	Maximum instantaneous current that is allowed to flow to the motor
Rated Speed*1	min ⁻¹	3000				Speed at the rated operating point
Max. Speed*1	min ⁻¹	4500				Highest possible speed
Torque Constant	Nm/Arms	0.413	0.645	0.682	0.699	Generated torque ratio for current flowing to the motor
Rotor Moment of Inertia	kg × m ² × 10 ⁻⁴	0.0634	0.330	0.603	1.50	Inertia moment at the rotor shaft
Rated Power Rate*1	kw/s	16.0	12.3	26.7	38.1	Motor output per unit time
Rated Angular Acceleration*1	rad/s ²	50200	19300	21100	15900	The theoretical angular acceleration (also called torque-to-inertia ratio) at the rated torque
Time Rating	Continuous					*Continuous rating* means that the temperature of the servomotor in continuous operation under specified conditions will not exceed a specified temperature or other limitation.
Thermal Class	B					Highest allowable temperature for armature winding: 130°C
Vibration Class	15µm or below					The maximum vibration amplitude of the motor expressed in units of micrometers on the condition that the vibration is measured with a vibrometer parallel to the shaft and in two directions perpendicular to the shaft.
Withstand Voltage	1500 VAC for one minute					-
Insulation Resistance	500 VDC, 10 MΩ min.					-
Enclosure	Totally enclosed, self-cooled, IP55 (excluding shaft opening and connectors)					Level of protection from dust and water drops
Impact Resistance	Impact acceleration: 490 m/s ² in three directions – vertical, side to side, and front to back. Impact occurrences: 2					Impact resistance of the motor in three directions (up and down, left and right, and back and forth) with the motor shaft mounted horizontally
Vibration Resistance	Vibration acceleration: 49 m/s ² in three directions – vertical, side to side, and front to back.					Vibration resistance of the motor in three directions (up and down, left and right, and back and forth) with the motor shaft mounted horizontally

*1: These items and speed/torque characteristics quoted in combination with an SJDE SERVOPACK are at an armature winding temperature of 100°C. Other values quoted at 20°C.

*2: The rated torques listed here are the values for the continuous allowable torque at 40°C with an aluminum heatsink (250 mm × 250 mm × 6 mm) attached.

■ Holding Brake Specifications

Servomotor Model: SJME-□□A		01	02	04	08	Description
Rated Voltage		24 VDC ± 10%				-
Holding Brake Moment of Inertia*	kg × m ² × 10 ⁻⁴	0.0075	0.064	0.171		-
Capacity	W	6	6.9	7.7		-
Min. Holding Torque (Static Friction Torque)	Nm	0.318	1.27	2.39		Torque against an external force to hold the shaft
Coil Resistance	Ω (at 20°C)	96	83	75		Resistance of the built-in coil in the brake
Rated Current	A (at 20°C)	0.25	0.29	0.32		Current that flows when the brake is released
Brake Release Time	ms	80 max.				Time from when the power for the holding brake is turned on until the brake is released.
Rise Time for Holding Torque	ms	100 max.				Time from when the power for the holding brake is turned off until the brake reaches the set torque.

*: To obtain the motor moment of inertia with a brake, add the holding brake moment of inertia to the rotor moment of inertia. The rated power rate and angular acceleration of the motor will change according to the motor moment of inertia.

Notes: 1 The holding brake is only used to hold the load and cannot be used to stop the servomotor.

2 Do not use the holding brake when the servo is on. Failure to observe this caution may result in an overload in the SERVOPACK or a decrease in the brake life.

■ Speed / Torque Characteristics

How to read a graph of speed and torque characteristics

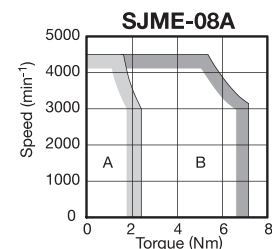
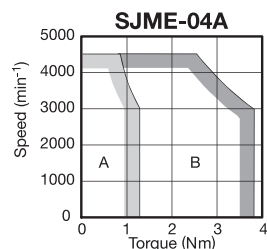
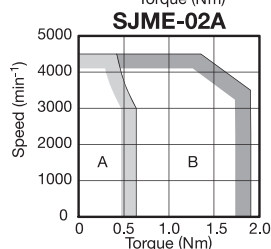
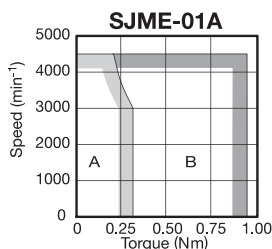
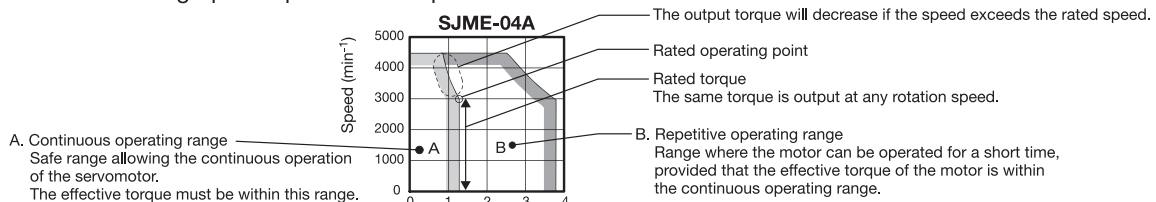

Note: Solid lines show the torque/speed characteristics of the servomotor at 200 VAC, and the broken lines show them at 230 VAC.

■ Dimensions Units: mm

● 100W

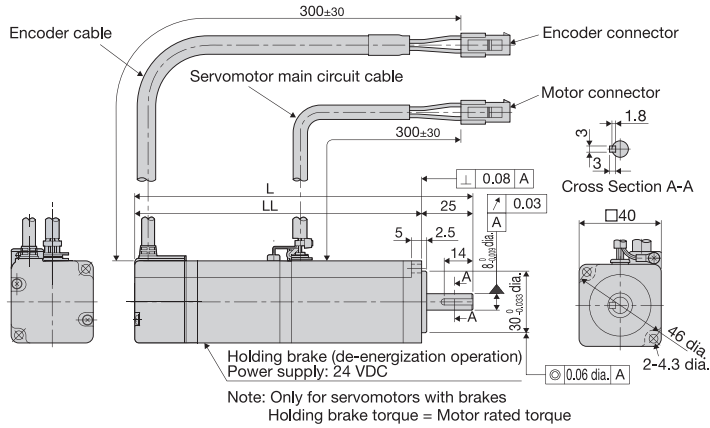

Type SJME-	L	LL	Approx. Mass kg
01AMA41	119	94	0.5
01AMA4C	164	139	0.8

Motor Connector Specifications



Plug:
5559-06P-210
Terminal (No.1 to 3, 5, 6):
5558T(chained) or 5558TL(detached)
Grounding Pin (No.4):
30490-2002(chained) or
30490-2012 (detached)

	No brake	With brake
1	Phase U Red	Phase U Red
2	Phase V White	Phase V White
3	Phase W Blue	Phase W Blue
4	F G Green/Yellow	F G Green/Yellow
5	-	Brake Red
6	-	Brake Black

Encoder Connector Specifications



Plug:
5559-12P-210
Terminal:
5558T2(chained) or
5558T2L(detached)

1	PGSV	Red
2	PG0V(GND)	Black
3	Phase A+	Blue
4	Phase A-	Blue/White
5	Phase B+	Yellow
6	Phase B-	Yellow/White
7	Phase Z	Purple
8	Phase U	Gray
9	Phase V	Green
10	Phase W	Orange
11	-	-
12	FG	Shield

● 200W to 750W

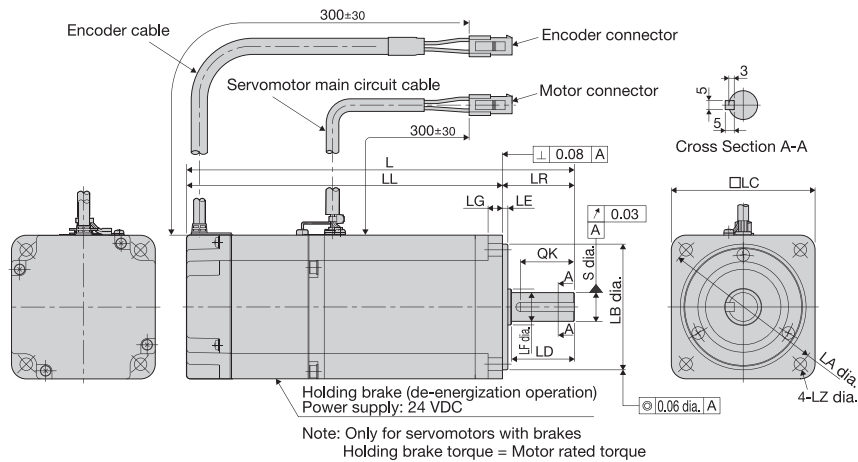

Type SJME-	L	LL	LR	LG	LE	S	LB	LC	LD	LF	LA	LZ	QK	Approx. Mass kg
02AMA41	125.5	95.5	30	6	3	14 ⁰ _{-0.011}	50 ⁰ _{-0.039}	60	-	-	70	5.5	20	0.9
02AMA4C	165.5	135.5												1.5
04AMA41	148.5	118.5	40	8	3	16 ⁰ _{-0.011}	70 ⁰ _{-0.046}	80	35	20	90	7	30	1.3
04AMA4C	188.5	158.5												1.9
08AMA41	173	133	216	176	-	-	-	-	-	-	-	-	-	2.6
08AMA4C	216	176												3.5

SERVOPACKs



■ Ratings and Specifications

SERVOPACK model		SJDE-	01APA	02APA	04APA	08APA	Description
Max. applicable servomotor capacity [kW]			0.1	0.2	0.4	0.75	Motor capacity that the SERVOPACK can drive.
Continuous output current [Arms]			0.84	1.1	2.0	3.7	Current that the SERVOPACK can output continuously.
Instantaneous max. output current [Arms]			2.5	3.3	6.0	11.1	Maximum current that the SERVOPACK can output instantaneously.
Input power supply (for main circuit and control circuit)	Voltage	Single-phase 200 V to 230 VAC, +10% to -15%					-
	Frequency	50/60Hz 5%					-
Capacity at rated output [kVA]			0.40	0.75	1.2	2.2	Power supply capacity required to operate a motor at the rated output.
Power loss at rated output [W]			14	16	24	35	Electric power emitted as heat from the SERVOPACK while operating the motor at the rated torque and rated speed.
Input control method		Capacitor-input type, single-phase full-wave rectification with resistance to prevent inrush currents.					-
Output control method		PWM control, sine wave power driven system					-
Feedback		Analog output encoder					Speed or position detector fixed on the motor shaft opposite the load side.
Allowable load inertia [kgm ²]*1			0.6×10 ⁻⁴	3×10 ⁻⁴	5×10 ⁻⁴	10×10 ⁻⁴	Maximum allowable moment of inertia converted into the moment of inertia at the motor shaft of the machine.
I/O Signals	Input signal for reference Designated pulse type and pulse resolution with PULSE switch.	Pulse type	Select one of the following signals: 1. CCW + CW 2. Sign + pulse train 3. CCW + CW (logic reversal) 4. Sign + pulse train (logic reversal)				Type of pulse train signal to drive motor, input into the SERVOPACK. For CCW+CW, input both forward and reverse rotation pulse trains.
		Pulse resolution	Select one of the following signals: 1. 1000 pulses/rev (Open collector/line driver) 75 kpps max. 2. 2500 pulses/rev (Open collector/line driver) 187.5 kpps max. 3. 5000 pulses/rev (Line driver) 375 kpps max. 4. 10000 pulses/rev (Line driver) 750 kpps max.				Number of reference pulses required to rotate the motor one turn
	Clear input signal	Clears the positioning error when turned ON.					-
	Servo ON input signal	Turns the servomotor on or off.					-
	Alarm output signal	OFF if an alarm occurs. Note: OFF for 2s when power is turned ON.					-
	Brake output signal	External signal to control brakes. Turn ON to release the brake.					-
	Positioning completed output signal	ON if the current position is equal to the reference position 10 pulses.					-
Built-in functions	Origin output signal	ON if the motor is at the origin. (Width: 1/500 rev) Note: Use the pulse edge that changes the signal from OFF to ON.					Only one point of origin per rotation
	Dynamic brake (DB)	Operated at main power OFF, servo alarm, servo OFF. (OFF after motor stops; ON if the motor power is off.)					Method that stops the motor by short-circuiting the internal circuit of the SERVOPACK.
	Regenerative processing	Optional (If the regenerated energy is too large, install a regenerative unit.)					Function to consume rotational power generated when the motor is rotated by external force. This function is required for a high load moment of inertia.
	Protection*2	Speed errors, overload, encoder errors, voltage errors, overcurrents, disablement of the built-in cooling fan, system errors. Note: No built-in circuit for ground protection.					-
	LED display	5 (PWR, REF, AL1, AL2, AL3)					-
Reference filter		Select one of eight levels with FIL switch.					-
Cooling method		Forced cooling (built-in fan)					-
Operating temperature		0°C to +55°C					-
Operating humidity		90% RH or less (with no condensation)					-
Storage temperature		-20°C to +70°C					-
Storage humidity		90% RH or less (with no condensation)					-
Installation site		<ul style="list-style-type: none"> Free of corrosive gases Free of dust and iron powder Clean and dry 					-
Altitude		1000 m or below					-
Vibration resistance		4.9m/s ²					-
Shock resistance		19.6m/s ²					-
Operating conditions		Installation category (overvoltage category): II Pollution degree: 2 Protection class: IP1X (EN50178)					-

*1: Be sure to use the motor with in the allowable load inertia moment.

The operation of the motor will become unstable if the allowable load Inertia moment is exceeded.

*2: The ground protection circuit is designed for ground fault inside the motor windings while the motor is running.

Therefore, it may not protect the system under the following conditions.

- A low-resistance ground fault occurs in the main circuit cable or in the connector of the cable for the servomotor.
- The power supply is turned ON during a ground fault.

To configure a safer system, install an earth leakage breaker to protect against both overloads and shortcircuits, or install an earth leakage breaker for ground protection and a molded-case circuit breaker.

■ Dimensions Units: mm

● SJDE-01, 02 (100W, 200W)

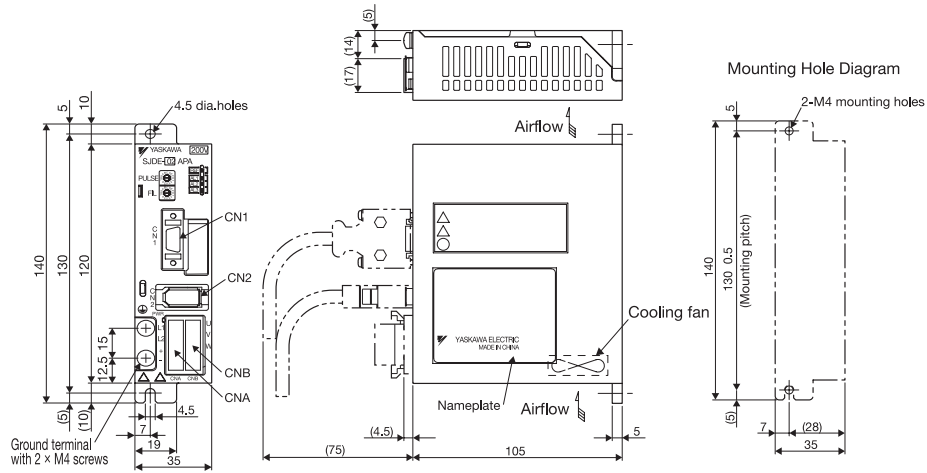

● SJDE-04 (400W)

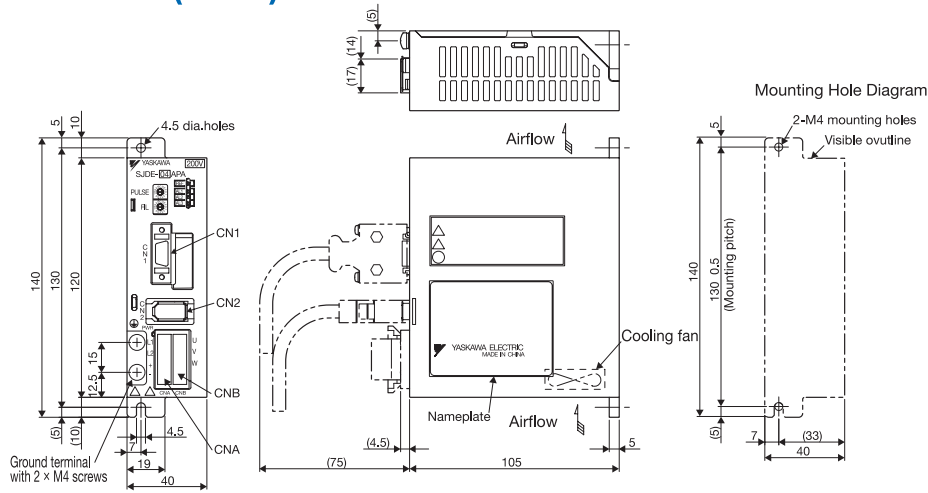

● SJDE-08 (750W)

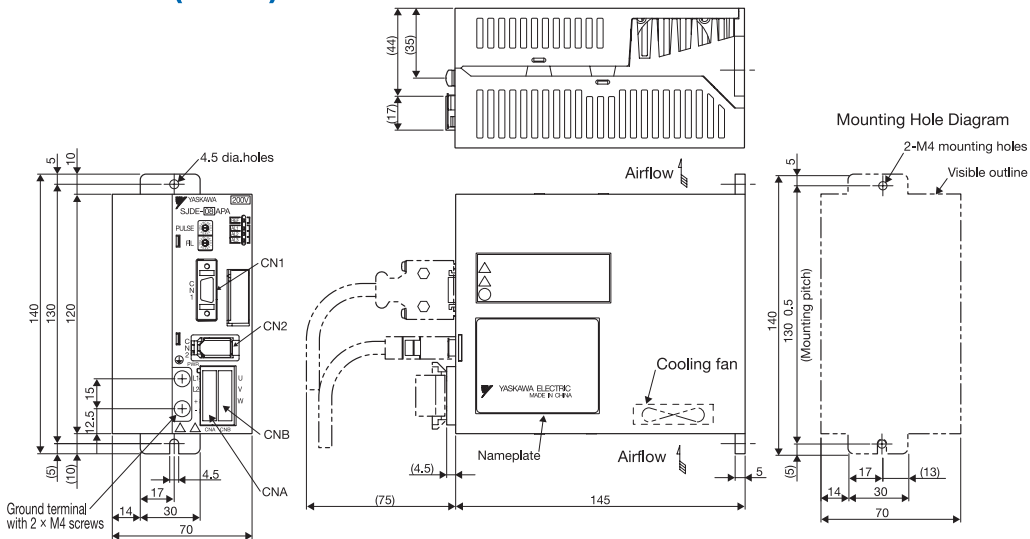



Yaskawa Electric Europe GmbH

Am Kronberger Hang 2
65824 Schwalbach
Deutschland / Germany

+49 (0)6196 / 569 300
info@yaskawa.de
www.yaskawa.eu.com

YEG-KAEPS80000023B

Specifications are subject to change without notice
for ongoing product modifications and improvements.
© YASKAWA ELECTRIC CORPORATION. All rights reserved.

