

# iC-MQ PROGRAMMABLE 9-BIT Sin/Cos INTERPOLATION IC WITH RS422 DRIVER

preliminary



Rev B1, Page 1/36

## FEATURES

- ◆ Latency-free sine-to-digital conversion to 400 angle steps
- ◆ 200 kHz input frequency for interpolation factors of x1 to x5 (10 kHz for x100)
- ◆ Flexible pin assignment due to signal path multiplexers
- ◆ PGA inputs for differential and single-ended signals
- ◆ Variable input resistance for current/voltage conversion
- ◆ Signal conditioning for offset, amplitude and phase
- ◆ Controlled 50 mA current source for LED or MR sensor supply
- ◆ Fault-tolerant RS422 outputs with 50 mA sink/source drive current
- ◆ Preselectable minimum phase distance for spike-proof counter stimulus
- ◆ Zero signal conditioning and electronic index pulse generation
- ◆ Signal and operation monitoring with configurable alarm output, output shutdown and error storage
- ◆ I<sup>2</sup>C multimaster interface for in-circuit calibration and parameters (EEPROM)
- ◆ Adjustable overtemperature alarm and shutdown
- ◆ Supply from 4.3 to 5.5 V, operation from -25(-40) to +100 °C
- ◆ Reverse polarity proof including the sub-system

## APPLICATIONS

- ◆ Optical and magnetic position sensors
- ◆ Angle encoders
- ◆ Linear scales

## PACKAGES

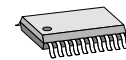

TSSOP20

## BLOCK DIAGRAM

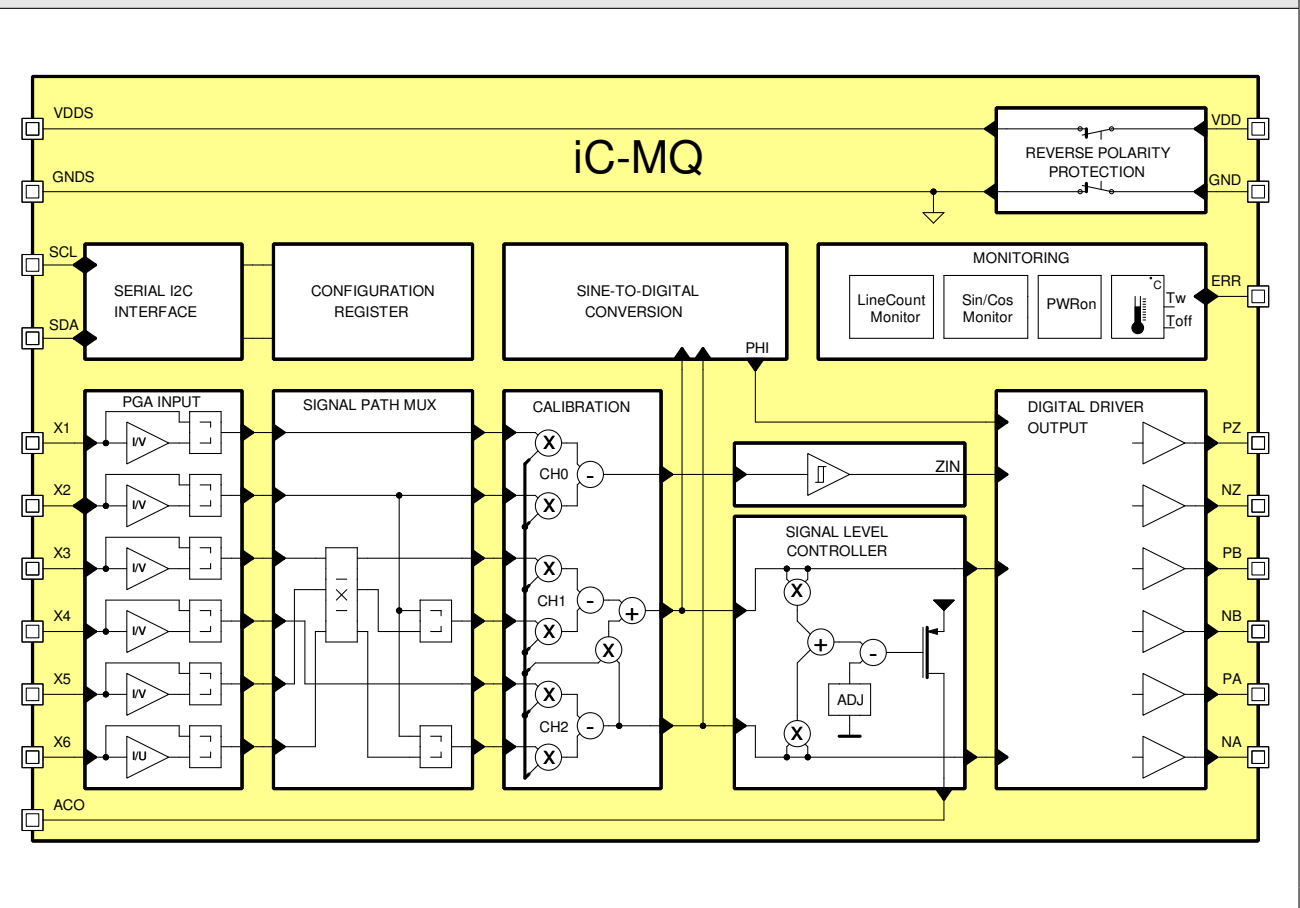

## DESCRIPTION

Interpolator iC-MQ is a non-linear A/D converter which digitizes sine/cosine sensor signals using a count-safe tracking conversion principle with selectable resolution and hysteresis. The angle resolution per sine period can be set using SELRES; up to 400 angle steps are possible (see page 24).

The angle position is output incrementally by differential RS422 drivers as an encoder quadrature signal with a zero pulse or, if selected, as a counter signal for devices compatible with 74HC191 or 74HC193.

The zero pulse is generated electronically when an enable has been set by the X1/X2 inputs. This pulse can be configured extensively: both in its relative position to the input signal with regard to the logic gating with A and/or B and in its width from 90° to 360° (1/4 to 1 T).

A preselectable minimum transition distance permits glitch-free output signals and prevents counting errors which in turn boosts the noise immunity of the position encoder.

Programmable instrumentation amplifiers with selectable gain levels allow differential or single-ended, referenced input signals; via input X2 the external reference can be used as reference voltage for the offset correction.

The modes of operation differentiate between high impedance (V modes) and low impedance (I modes). This adaptation of the iC to voltage or current signals enables MR sensor bridges or photosensors to be directly connected up to the device. The optical scanning of low resolution code discs is also supported by the reference function of input X2; these discs do not evaluate tracks differentially but in comparison with a reference photodiode.

The integrated signal conditioning unit allows signal amplitudes and offset voltages to be calibrated accurately and also any phase error between the sine and cosine signals to be corrected. The channel for the zero signal can be configured separately.

A control signal is generated from the conditioned signals which can track the transmitting LED of optical encoders via the integrated 50 mA driver stage (output ACO). If MR sensors are connected this driver stage can also track the power supply of the measuring bridges. By tracking the sensor energy supply any temperature and aging effects are compensated for, the input signals stabilized and the exact calibration of the input signals is maintained. This enables a constant accuracy of the interpolation circuit across the entire operating temperature range.

When control limits are reached, these can be indicated at the maskable error pin ERR. Faults such as overdrive, wire breakage, short circuiting, dirt or aging, for example, are logged.

iC-MQ includes extensive self-test and system diagnosis functions which check whether the sensor is working properly or not. For all error events the user can select whether the fault be displayed at error pin ERR or the outputs shutdown. At the same time errors can be stored in the EEPROM to enable failures to be diagnosed at a later stage. For encoder applications the line count of the code disc, the sensor signal regarding signal level and frequency and the operating temperature can be monitored, for example, the latter using an adjustable on-chip sensor.

Display error pin ERR is bidirectional; a system fault recognized externally can be recorded and also registered in the error memory.

iC-MQ is protected against reverse polarity and offers its monitored supply voltage to the external circuit, thus extending the protection to the system (for load currents to 20 mA). Reverse polarity protection also covers the short-circuit-proof line drivers so that an unintentional faulty wiring during initial operation is tolerated.

On being activated the device configuration is loaded via the serial configuration interface from an external EEPROM and verified by a CRC. A microcontroller can also configure iC-MQ; the implemented interface is multimaster-competent and enables direct RAM access.

**PACKAGES**

**PIN CONFIGURATION TSSOP20**

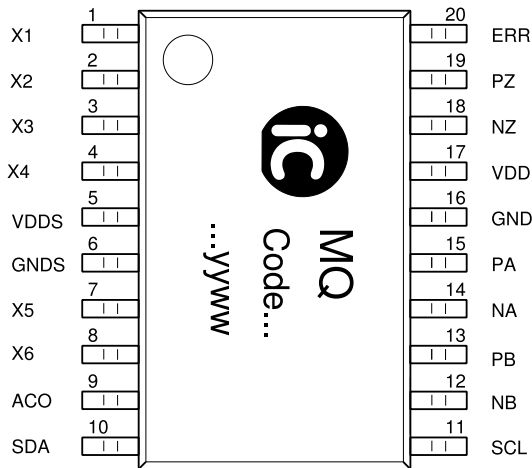

**PIN FUNCTIONS**

No.	Name	Function
1	X1	Signal Input 1 (Index +)
2	X2	Signal Input 2 (Index -)
3	X3	Signal Input 3
4	X4	Signal Input 4
5	VDDS	Switched Supply Output (reverse polarity proof, load to 20 mA max.)
6	GNDS	Switched Ground (reverse polarity proof)
7	X5	Signal Input 5
8	X6	Signal Input 6
9	ACO	Signal Level Controller, high-side current source output
10	SDA	Serial Configuration Interface, data line
11	SCL	Serial Configuration Interface, clock line
12	NB	Incremental Output B-
13	PB	Incremental Output B+
14	NA	Incremental Output A-
15	PA	Incremental Output A+
16	GND	Ground
17	VDD	+4.3...5.5 V Supply Voltage
18	NZ	Incremental Output Z-
19	PZ	Incremental Output Z+
20	ERR	Error Signal (In/Out) / Test Mode Trigger Input

### ABSOLUTE MAXIMUM RATINGS

These ratings do not imply operating conditions; functional operation is not guaranteed. Beyond these ratings device damage may occur.

Item No.	Symbol	Parameter	Conditions			Unit
				Min.	Max.	
G001	V()	Voltage at VDD, PA, NA, PB, NB, PZ, NZ, SCL, SDA, ACO		-6	6	V
G002	V()	Voltage at ERR		-6	8	V
G003	V()	Pin-Pin Voltage			6	V
G004	V()	Voltage at X1...X6, SCL, SDA		-0.3	VDDS + 0.3	V
G005	I(VDD)	Current in VDD		-20	400	mA
G006	I()	Current in VDDS, GNDS		-50	50	mA
G007	I()	Current in X1...X6, SCL, SDA, ERR		-20	20	mA
G008	I()	Current in PA, NA, PB, NB, PZ, NZ		-100	100	mA
G009	I(ACO)	Current in ACO		-100	20	mA
G010	Vd()	ESD Susceptibility at all pins	HBM 100 pF discharged through 1.5 kΩ		2	kV
G011	T <sub>j</sub>	Junction Temperature		-40	150	°C
G012	T <sub>s</sub>	Storage Temperature		-40	150	°C

### THERMAL DATA

Item No.	Symbol	Parameter	Conditions	Min.	Typ.	Max.	Unit
T01	T <sub>a</sub>	Operating Ambient Temperature Range (extended range to -40 °C on request)		-25		100	°C

All voltages are referenced to pin GNDS unless otherwise stated.

All currents into the device pins are positive; all currents out of the device pins are negative.

**ELECTRICAL CHARACTERISTICS**

Operating Conditions: VDD = 4.3 ... 5.5 V, T<sub>j</sub> = -40 °C ... 125 °C, IBN calibrated to 200 μA, unless otherwise stated

Item No.	Symbol	Parameter	Conditions				Unit
				Min.	Typ.	Max.	
<b>Total Device</b>							
001	V(VDD)	Permissible Supply Voltage	Load current I(VDDS) to 10 mA Load current I(VDDS) to 20 mA	4.3 4.5		5.5 5.5	V V
002	I(VDD)	Supply Current	T <sub>j</sub> = -40...125 °C, no load T <sub>j</sub> = 27 °C, no load		12	25	mA mA
003	I(VDDS)	Permissible Load Current VDDS		-20		0	mA
004	Vc()hi	Clamp-Voltage hi at all pins				11	V
005	Vc()hi	Clamp-Voltage hi at Inputs X1...X6, SCL, SDA	Vc()hi = V() - V(VDD), I() = 4 mA	0.3		1.2	V
006	Vc()lo	Clamp-Voltage lo at all pins	I() = -4 mA	-1.2		-0.3	V
<b>Signal Conditioning, Inputs X1...X6 (CH1, CH2: i = 12, CH0: I = 0)</b>							
101	Vin()sig	Permissible Input Voltage Range	RINi() = 0x01	0.75		VDDS - 1.5 VDDS	V
			RINi() = 0x09	0		V	
102	iin()sig	Permissible Input Current Range	RINi(0) = 0; BIASi = 0	-300		-10	μA
			RINi(0) = 0; BIASi = 1	10		300	μA
103	lin()	Input Current	RINi() = 0x01	-10		10	μA
104	Rin()	Input Resistance vs. VREFin	T <sub>j</sub> = 27 °C;				
			RINi(3:0) = 0x09	16	20	24	kΩ
			RINi(3:0) = 0x00	1.1	1.6	2.1	kΩ
			RINi(3:0) = 0x02	1.6	2.3	3.0	kΩ
			RINi(3:0) = 0x04	2.2	3.2	4.2	kΩ
			RINi(3:0) = 0x06	3.2	4.6	6.0	kΩ
105	TC(Rin)	Temperature Coefficient of Rin			0.15		%/K
106	VREFin()	Reference Voltages VREFin0, VREFin12	RINi(0) = 0, BIASi = 1	1.35	1.5	1.65	V
			RINi(0) = 0, BIASi = 0	2.25	2.5	2.75	V
			Version iC-MQ 3: RINi(0) = 0, BIASi = 1	1.8	2.0	2.2	V
		RINi(0) = 0, BIASi = 0	2.7	3.0	3.3	V	
107	G0, G12	Selectable Gain Factors	RINi(3) = 0	2		100	
			RINi(3) = 1	0.5		25	
108	Gdiff	Relative Gain Ratio CH1 vs. CH2	GF2 = 0x10, GF1 = 0x0...0x7F	39		255	%
109	ΔG	Step Width Of Fine Gain Adjustment	for CH0 for CH1 for CH2		1.06 1.015 1.06		
110	INL(Gi)	Integral Linearity Error of Gain Adjustment		-1.06		1.06	
111	Vin()diff	Recommended Differential Input Voltage	Vin()diff = V(PCHx) - V(NCHx); RINi(3) = 0 RINi(3) = 1	10 40		500 2000	mVpp mVpp
112	Vin()os	Input Offset Voltage	referred to side of input		25		μV
113	VOScal	Offset Calibration Range	referenced to the selected source (VOS0 resp. VOS12); ORi = 00 ORi = 01 ORi = 10 ORi = 11		±100 ±200 ±600 ±1200		%V() %V() %V() %V()
114	ΔOF0	CH0 Offset Calibration Step Width	referenced to the selected source VOS0; OR0 = 0x0		3.2		%
115	ΔOF12	CH1/2 Offset Calibration Step Width	referenced to the selected source VOS12; OR12 = 0x0		0.79		%
116	INL(OFi)	Integral Linearity Error of Offset Calibration		-5		5	LSB
117	PHI12	Phase Error Calibration Range	CH1 vs. CH2		±20.2		°
118	ΔPHI12	Phase Error Calibration Step Width			0.63		°

**ELECTRICAL CHARACTERISTICS**

Operating Conditions: VDD = 4.3 ... 5.5 V, T<sub>j</sub> = -40 °C ... 125 °C, IBN calibrated to 200 μA, unless otherwise stated

Item No.	Symbol	Parameter	Conditions	Min.	Typ.	Max.	Unit
119	INL(PHI12)	Integral Linearity Error of Phase Calibration		-0.8		0.8	°
120	fin()	Permissible Input Frequency	analog signal path	200			kHz
<b>Sine-To-Digital Conversion</b>							
201	AAabs	Absolute Angle Accuracy	referenced to 360° input signal, ideal waveform, quasi static signals, adjusted signal conditioning, SELHYS = 0		0.9	1.8	°
202	AArel	Relative Angle Accuracy	referenced to A/B output period, ideal waveform, quasi static signals; at 4 edges per period at 100 edges per period at 384 edges per period at 400 edges per period		<0.5	10	%
203	AAR	Repeatability	see 201; VDD = const., T <sub>j</sub> = const.		0.1		°
<b>Line Driver Outputs PA, NA, PB, NB, PZ, NZ</b>							
501	Vs(hi)	Saturation Voltage hi	Vs() = VDD - V(); SIK(1:0) = 00, I() = -1.2 mA SIK(1:0) = 01, I() = -4 mA SIK(1:0) = 10, I() = -20 mA SIK(1:0) = 11, I() = -50 mA			200 200 400 700	mV mV mV mV
502	Vs(lo)	Saturation Voltage lo	SIK(1:0) = 00, I() = 1.2 mA SIK(1:0) = 01, I() = 4 mA SIK(1:0) = 10, I() = 20 mA SIK(1:0) = 11, I() = 50 mA			200 200 400 700	mV mV mV mV
503	Isc(hi)	Short-Circuit Current hi	V() = 0 V; SIK(1:0) = 00 SIK(1:0) = 01 SIK(1:0) = 10 SIK(1:0) = 11	-4 -12 -60 -150		-1.2 -4 -20 -50	mA mA mA mA
504	Isc(lo)	Short-Circuit Current lo	V() = VDD; SIK(1:0) = 00 SIK(1:0) = 01 SIK(1:0) = 10 SIK(1:0) = 11	1.2 4 20 50		4 12 60 150	mA mA mA mA
505	tr()	Rise Time	RL = 100 Ω to GND; SSR(1:0) = 00 SSR(1:0) = 01 SSR(1:0) = 10 SSR(1:0) = 11	5 5 20 50		20 40 140 350	ns ns ns ns
506	tf()	Fall Time	RL = 100 Ω to VDD; SSR(1:0) = 00 SSR(1:0) = 01 SSR(1:0) = 10 SSR(1:0) = 11	5 5 30 50		20 40 140 350	ns ns ns ns
507	I <sub>lk</sub> (tri)	Leakage Current	TRIDL(1:0) = 11 (tristate)		20	100	μA
508	I <sub>lk</sub> (rev)	Leakage Current	reversed supply voltage		100		μA
509	R <sub>in</sub> (cal)	Test Signal Source Impedance	Op. modes <i>Calibration 1, 2, 3</i>		2.5	4	kΩ
510	I(cal)	Permissible Test Signal Load	Op. modes <i>Calibration 1, 2, 3</i>	-3		3	μA
511	t <sub>clk</sub> (lo)	Clock Signal Low-Pulse Duration for CP, CPD, CPU	Op. mode <i>Mode 191/193</i>		50		ns
512	ΔMTD()	Minimum Phase Distance Tolerance	referenced to nominal value	-25		25	%

**ELECTRICAL CHARACTERISTICS**

Operating Conditions: VDD = 4.3 ... 5.5 V, T<sub>j</sub> = -40 °C ... 125 °C, IBN calibrated to 200 µA, unless otherwise stated

Item No.	Symbol	Parameter	Conditions	Min.	Typ.	Max.	Unit
<b>Signal Level Controller ACO</b>							
601	Vs(hi)	Saturation Voltage hi	Vs() = VDD - V(); ADJ(8:0) = 0x19F, I() = -5 mA ADJ(8:0) = 0x1BF, I() = -10 mA ADJ(8:0) = 0x1DF, I() = -25 mA ADJ(8:0) = 0x1FF, I() = -50 mA			1 1 1 1.2	V V V V
602	Isc(hi)	Short-Circuit Current hi	V() = 0 ... VDD - 1 V; ADJ(8:0) = 0x19F ADJ(8:0) = 0x1BF ADJ(8:0) = 0x1DF V() = 0 ... VDD - 1.2 V; ADJ(8:0) = 0x1FF	-10 -20 -50 -100		-5 -10 -25 -50	mA mA mA mA
<b>Bias Current Source and Reference Voltages</b>							
801	IBN	Bias Current Source	Calibration 1, I(NB) vs. VDDS; CFGIBN = 0x0 CFGIBN = 0xF IBN calibrated at T = 25 °C	110 180	200	370 220	µA µA µA
802	VBG	Internal Bandgap Reference		1.2	1.25	1.3	V
803	VPAH	Reference Voltage		45	50	55	%VDDS
804	V05	Reference Voltage V05		450	500	550	mV
805	V025	Reference Voltage V025			50		%V05
<b>Power-Down-Reset</b>							
901	VDDon	Turn-on Threshold VDD, Power-Up-Enable	increasing voltage at VDD	3.6	4.0	4.3	V
902	VDDoff	Turn-off Threshold VDD, Power-Down-Reset	decreasing voltage at VDD	3.0	3.5	3.8	V
903	VDDhys	Hysteresis		0.4			V
<b>Error Signal Input/Output, Pin ERR</b>							
B01	Vs(lo)	Saturation Voltage lo	versus GND, I() = 4 mA			0.4	V
B02	Isc(lo)	Short-Circuit Current lo	versus GND, V(ERR) ≤ VDD	4	5	7	mA
B03	Isc()	Low-Side Current Source For Data Output	versus GND, V(ERR) > VTMon L state Z state		2 0		mA mA
B04	Vt(hi)	Input Threshold Voltage hi	versus GND			2	V
B05	Vt(lo)	Input Threshold Voltage lo	versus GND	0.8			V
B06	Vt(hys)	Input Hysteresis	Vt(hys) = Vt(hi) - Vt(lo)	300	500		mV
B07	Ipu()	Input-Pull-Up-Current	V() = 0...VDD - 1 V, EPU = 1	-400	-300	-200	µA
B08	Vpu()	Pull-Up-Voltage	Vpu() = VDD - V(), I() = -5 µA, EPU = 1			0.4	V
B09	VTMon	Test Mode Turn-on Threshold	increasing voltage at ERR			VDD + 2	V
B10	VTMoff	Test Mode Turn-off Threshold	decreasing voltage at ERR	VDD + 0.5			V
B11	VTMhys	Test Mode Threshold Hysteresis	VTMhys = VTMon - VTMoff	0.15	0.3		V
B12	fclk()	Data Output Signal Frequency	ENFAST = 0 ENFAST = 1	120 480	160 640	200 800	kHz kHz
B13	tp(ERR)in	Process Delay for System Error Message at ERR	upon power up (VDD > VDDon)		10		ms
<b>Reverse Polarity Protection and Supply Switches VDDS, GNDS</b>							
C01	Vs()	Saturation Voltage vs. VDD	Vs(VDDS) = VDD - V(VDDS); I(VDDS) = -10...0 mA I(VDDS) = -20...-10 mA			150 250	mV mV
C02	Vs()	Saturation Voltage vs. GND	Vs(GNDS) = V(GNDS) - GND; I(GNDS) = 0...10 mA I(GNDS) = 10...20 mA			150 200	mV mV
C03	Irev(VDD)	Reversed Polarity Current	V(VDD) = -5.5V...-4.3 V	-1		0	mA

**ELECTRICAL CHARACTERISTICS**

Operating Conditions: VDD = 4.3 ... 5.5 V, Tj = -40 °C ... 125 °C, IBN calibrated to 200 µA, unless otherwise stated

Item No.	Symbol	Parameter	Conditions				Unit
				Min.	Typ.	Max.	
<b>Serial Configuration Interface SCL, SDA</b>							
D01	Vs()lo	Saturation Voltage lo	I = 4 mA			400	mV
D02	Isc()lo	Short-Circuit Current lo		4		75	mA
D03	Vt()hi	Input Threshold Voltage hi				2	V
D04	Vt()lo	Input Threshold Voltage lo		0.8			V
D05	Vt()hys	Input Hysteresis	Vt()hys = Vt()hi - Vt()lo	300	500		mV
D06	Ipu()	Input Pull-Up Current	V() = 0...VDD5 - 1 V	-600	-300	-60	µA
D07	Vpu()	Pull-Up Voltage	Vpu() = VDD5 - V(), I() = -5 µA			0.4	V
D08	fclk()	Clock Frequency at SCL	ENFAST = 0 ENFAST = 1	60 240	80 320	100 400	kHz kHz
D09	tbusy()cfg	Duration of Startup Configuration	IBN not calibrated, EEPROM access without read failure; ENFAST = 0 ENFAST = 1		18 14	24 20	ms ms
D10	tbusy()err	Max. Duration of Startup Configuration	no EEPROM		80	150	ms
D11	tp()	Start Of Master Activity On I2C Protocol Error	SCL without clock signal: V(SCL) = constant; IBN not calibrated IBN calibrated to 200 µA	25 64	80 80	240 110	µs µs
<b>Temperature Monitoring</b>							
E01	VTs	Temperature Sensor Voltage	VTs() = VDD5 - V(PA), Calibration 3, without Load; Tj = -40 °C Tj = 27 °C Tj = 100 °C	740 620 490	770 650 520	790 670 540	mV mV mV
E02	TCs	Temp. Co. Temperature Sensor Voltage			-1.8		mV/K
E03	VTth	Temperature Warning Activation Threshold	VTth() = VDD5 - V(NA), Tj = 27 °C, Calibration 3, without Load; CFGTA(3:0) = 0x0 CFGTA(3:0) = 0xF	260 470	310 550	360 630	mV mV
E04	TCth	Temp. Co. Temperature Warning Activation Threshold			0.06		%/K
E05	Tw	Warning Temperature	CFGTA(3:0) = 0x0 CFGTA(3:0) = 0xF	125	140 65	80	°C °C
E06	Thys	Warning Temperature Hysteresis	80 °C < Tj < 125 °C	10	15	25	°C
E07	ΔT	Relative Shutdown Temperature	ΔT = Toff - Tw	5	15	25	°C

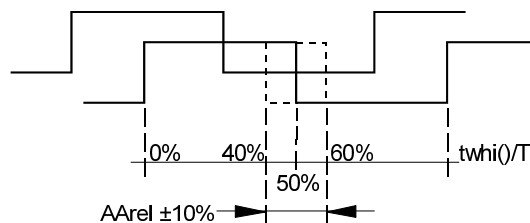

Figure 1: Definition of relative angle error

**PROGRAMMING**

<b>Register Map, Overview</b> .....	Page 10	<b>Signal Conditioning CH0 (X1, X2)</b> .....	Page 22
<b>Serial Configuration Interface</b> .....	Page 12	GR0:	Gain Range CH0 (coarse)
ENFAST:	I <sup>2</sup> C Fast Mode Enable	GF0:	Gain Factor CH0 (fine)
ENSL:	I <sup>2</sup> C Slave Mode Enable	VOS0:	Offset Reference Source CH0
DEVID:	Device ID of EEPROM providing the chip configuration data (e.g. 0x50)	OR0:	Offset Range CH0 (coarse)
CHKSUM:	CRC of chip configuration data (address range 0x00 to 0x2F)	OF0:	Offset Factor CH0 (fine)
CHPREL:	Chip Release	<b>Signal Level Controller</b> .....	Page 23
<b>Calibration</b> .....	Page 14	ADJ:	Setup of ACO Output Function
CFGIBN:	Bias Current	<b>Sine-To-Digital Conversion</b> .....	Page 24
CFGTA:	Temperature Monitoring	SELRES:	Resolution
<b>Operating Modes</b> .....	Page 15	SELHYS:	Hysteresis
MODE:	Operating Mode	<b>Quadrature Output Logic</b> .....	Page 25
<b>Input Configuration and Signal Path Multiplexer</b> .....	Page 17	CFGABZ:	Output Logic
INMODE:	Diff./Single-Ended Input Mode	CFGZPOS:	Zero Signal Positioning
RIN12:	I/V Mode and Input Resistance CH1, CH2	ENZFF:	Zero Signal Synchronisation
BIAS12:	Reference Voltage CH1, CH2	<b>Quadrature Output Settings</b> .....	Page 25
RIN0:	I/V Mode and Input Resistance CH0	MTD:	Minimum Phase Distance
BIAS0:	Reference Voltage CH0	SIK:	Driver Short-Circuit Current
BIASEX:	Input Reference Selection	SSR:	Driver Slew Rate
INVZ:	Index Signal Inversion	TRIHL:	Driver Mode
MUXIN:	Input-To-Channel Assignment: X3...X6 to CH1, CH2	<b>Error Monitoring and Alarm Output</b> .....	Page 28
<b>Signal Conditioning CH1, CH2 (X3...X6)</b> ...	Page 19	EMTD:	Minimal Alarm Indication Time
GR12:	Gain Range CH1, CH2 (coarse)	EPH:	Alarm Input/Output Logic
GF1:	Gain Factor CH1 (fine)	EPU:	Alarm Output Pull-Up Enable
GF2:	Gain Factor CH2 (fine)	EMASKA:	Error Event Mask for Alarm Indication
VOS12:	Offset Reference Source CH1, CH2	EMASKE:	Error Event Mask for EEPROM Savings
VDC1:	Intermediate Voltage CH1	EMASKO:	Error Event Mask for Driver Shutdown
VDC2:	Intermediate Voltage CH2	PDMODE:	Driver Reactivation After Cycling Power
OR1:	Offset Range CH1 (coarse)	LINECNT:	Line Count (Pulses) Between 2 Zero Pulses
OF1:	Offset Factor CH1 (fine)	ERR1:	First Saved Error
OR2:	Offset Range CH2 (coarse)	ERR2:	Last Saved Error
OF2:	Offset Factor CH2 (fine)	ERR3:	Error History (of all enabled events, see EMASKE)
PH12:	Phase Correction CH1 vs. CH2	<b>Test Mode</b> .....	Page 30
		EMODE:	Test Mode Functions
		EMODE2:	Test Mode Functions
		END:	Configuration Enable

**REGISTER MAP**

OVERVIEW								
Adr	Bit 7	Bit 6	Bit 5	Bit 4	Bit 3	Bit 2	Bit 1	Bit 0
<b>Serial Configuration Interface</b>								
0x00	ENFAST	DEVID(6:0)						
<b>Calibration</b>								
0x01	CFGIBN(3:0)				CFGTA(3:0)			
<b>Operating Mode</b>								
0x02	END	1	0	ENZFF	MODE(3:0)			
<b>Input Configuration</b>								
0x03	0	0	0	0	MUX(3:0)			
<b>Signal Conditioning CH1, CH2</b>								
0x04	GF2(4:0)					GR12(2:0)		
0x05	GF1(3:0)				0	0	0	0
0x06	VDC1(0)	0	0	0	0	GF1(6:4)		
0x07	0	0	0	VDC1(5:1)				
0x08	OR1(0)	VDC2(5:0)					0	
0x09	OF1(3:0)				0	0	0	OR1(1)
0x0A	0	0	OR2(1:0)		OF1(7:4)			
0x0B	OF2(6:0)							0
0x0C	PH12(2:0)			0	0	0	0	OF2(7)
0x0D	BIASEX(1:0)		0	1	1	PH12(5:3)		
0x0E	1	BIAS12	VOS12(1:0)		R12(3:0)			
<b>Signal Level Controller</b>								
0x0F	ADJ(0)	—	0	1	0	0	0	0
0x10	ADJ(8:1)							
<b>Signal Conditioning CH0</b>								
0x11	GF0(4:0)					GR0(2:0)		
0x12	OF0(5:0)					OR0(1:0)		
0x13	0	BIAS0	VOS0(1:0)		R0(3:0)			
<b>Error Monitoring and Alarm Output</b>								
0x14	EMASKA(7:0)							
0x15	EMODE(1:0)		EMTD(2:0)			EPH	EMASKA(9:8)	
0x16	EMASKO(7:0)							
0x17	EMASKE(3:0)				ENSL	EPU	EMASKO(9:8)	
0x18	EMODE2	PDMODE	EMASKE(9:4)					
<b>Zero Signal Output</b>								
0x19	CFGABZ(7:0)							
0x1A	CFGZPOS(7:0)							
<b>Sine-To-Digital Conversion, Minimum Phase Distance</b>								
0x1B	SELRES(7:0)							
0x1C	—	SELRES(14:8)						
0x1D	MTD(3:0)				SELHYS(3:0)			
<b>Output Driver Settings</b>								
0x1E	—	—	SIK(1:0)		SSR(1:0)		TRIHL(1:0)	

OVERVIEW								
Adr	Bit 7	Bit 6	Bit 5	Bit 4	Bit 3	Bit 2	Bit 1	Bit 0
<b>Line Counter</b>								
0x1F	LINECNT(7:0)							
0x20	—	—	LINECNT(13:8)					
<b>Reserved</b>								
0x21	0	0	0	0	1	0	0	0
0x22	—	—	—	—	—	—	—	—
0x23	—	—	—	—	—	—	—	—
0x24	reserved for application-specific OEM data							
0x25	reserved for application-specific OEM data							
0x26	reserved for application-specific OEM data							
0x27	reserved for application-specific OEM data							
0x28	reserved for application-specific OEM data							
0x29	reserved for application-specific OEM data							
0x2A	reserved for application-specific OEM data							
0x2B	reserved for application-specific OEM data							
0x2C	reserved for application-specific OEM data							
0x2D	reserved for application-specific OEM data							
0x2E	reserved for application-specific OEM data							
<b>Check Sum</b>								
0x2F	EEPROM: CHKSUM(7:0) / ROM: CHPREL(7:0)							
<b>Error Register</b>								
0x30	ERR1(7:0)							
0x31	ERR2(5:0)						ERR1(9:8)	
0x32	ERR3(3:0)				ERR2(9:6)			
0x33	—	—	ERR3(9:4)					

Table 4: Register layout

**SERIAL CONFIGURATION INTERFACE**

The serial configuration interface consists of the two pins SCL and SDA and enables read and write access to an EEPROM with an I<sup>2</sup>C interface. The readout clock rate can be selected using ENFAST.

ENFAST		Adr 0x00, bit 7
Code	Function	
0	Regular clock rate, f(SCL) approx. 80 kHz	
1	High clock rate, f(SCL) approx. 320 kHz	

Table 5: Clock Frequency I<sup>2</sup>C Interface

Once the supply has been switched on the iC-MQ outputs are high impedance (tristate\*) until a valid configuration is read out from the EEPROM using device ID 0x50.

Bit errors in the 0x00 to 0x2F memory section are pinpointed by the CRC deposited in register CHKSUM(7:0) (address 0x2F in the EEPROM; the CRC polynomial used is "1 0001 1101" with a start value of "1").

\*) Active low with typically 1.6 mA for version iC-MQ 3 (SIK = 00).

Should the read configuration data not be confirmed by the CRC, the readin process is repeated. If no valid configuration data is available after a fourth readin, iC-MQ terminates EEPROM access and switches to I<sup>2</sup>C slave mode. This switch takes place after 150 ms at the latest (see Electrical Characteristics, D11), for example when no EEPROM is connected.

For devices loading a valid configuration from the EEPROM register bit ENSL decides whether the I<sup>2</sup>C slave function is enabled or not.

ENSL		Adr 0x17, bit 3
Code	Function	
0	Normal operation	
1	I <sup>2</sup> C Slave Mode Enable (Device ID 0x55)	

Table 6: Config. Interface Mode

The device ID for the EEPROM can be entered in register DEVID(6:0) (address 0x00), from which iC-MQ will take its configuration after exiting test mode (see page 30). The DEVID stored therein is then accepted.

**Example of CRC Calculation Routine**

```

unsigned char ucDataStream = 0;
int iCRCPoly = 0x11D;
unsigned char ucCRC=0;
int i = 0;

ucCRC = 1; // start value !!!
for (iReg = 0; iReg<47; iReg ++ )
{
    ucDataStream = ucGetValue(iReg);
    for (i=0; i<=7; i++) {
        if ((ucCRC & 0x80) != (ucDataStream & 0x80))
            ucCRC = (ucCRC << 1) ^ iCRCPoly;
        else
            ucCRC = (ucCRC << 1);
        ucDataStream = ucDataStream << 1;
    }
}
    
```

**EEPROM Selection**

The following minimal requirements must be fulfilled:

- Operation from 3.3 to 5 V, I<sup>2</sup>C interface
- At least 512 bits, 64x8 (address range used is 0x00 to 0x3F)
- Support of *Page Write* with *Pages* of at least 4 bytes. Errors can otherwise not be saved to the EEPROM (EMASKE = 0x0).
- Device ID 0x50 "1010 000", no occupation of 0x55 (A2...A0 = 0). iC-MQ can otherwise not be accessed via 0x55 in I<sup>2</sup>C slave mode.

Recommended device: Atmel AT24C01B, ST M24C01W

**I<sup>2</sup>C Slave Mode (ENSL = 1)**

In this mode iC-MQ behaves like an I<sup>2</sup>C slave with the device ID 0x55 and the configuration interface permits write and read accesses to iC-MQ's internal registers.

For chip release verification purposes an identification value is stored under ROM address 0x2F; a write access to this address is not permitted.

<b>CHPREL</b> Adr 0x2F, bit 7:0 (ROM)	
Code	Chip Release
0x00	Not available
0x04	iC-MQ 3
0x08	iC-MQ X
0x09	iC-MQ X1

Table 7: Chip Release

<b>END</b> Adr 0x02, bit 7	
Code	Function
0	Sin/D converter and line driver disabled (RAM configuration data invalid)
1	Restart of Sin/D conversion, line driver active (RAM configuration data valid)

Table 8: Configuration Enable

<b>Register</b> Read access via I <sup>2</sup> C slave mode (ENSL = 1)	
Address	Content
0x00-0x21	Configuration: register addresses 0x00-0x21
0x22-0x2A	Not available
0x2B-0x2E	Configuration: register addresses 0x2B-0x2E
0x2F	Chip release (ROM)
0x30-0x33	Configuration: register addresses 0x30-0x33
0x34-0x3A	Not available
0x3B-0x3E	Configuration: register addresses 0x2B-0x2E
0x3F	Chip release (ROM)
0x40-0x43	Current error memory
0x44-0x7F	Not available

Table 9: RAM Read Access

<b>Register</b> Write access via I <sup>2</sup> C slave mode (ENSL = 1)	
Address	Access and conditions
0x00	Changes possible, no restrictions
0x01	Changes possible (wrong entries for CFGIBN can limit functions)
0x02	Changes to bits 6:0 are permitted only when Sin/D conversion is halted (END = 0, ie. bit 7); Restarting Sin/D conversion by changing END (bit 7) is permitted only with no changes of operating mode (bits 6:0 remain as set)
0x03-0x16	Changes possible, no restrictions
0x17	Changes to bits 7:4 and 2:0 are permitted (ENSL, bit 3 must be kept 1)
0x18	Changes possible, no restrictions
0x19-0x21	Changes possible when Sin/D conversion is halted (END = 0)
0x2B-0x2E	Changes possible, no restrictions
Others	No write access permitted

Table 10: RAM Write Access

**BIAS CURRENT SOURCE AND TEMPERATURE SENSOR CALIBRATION**

**Bias Current**

The calibration of the bias current source in operation mode *Calibration 1* (see Table 13) is prerequisite for adherence to the given electrical characteristics and also instrumental in the determination of the chip timing (e.g. clock frequency at SCL). For setup purposes the IBN bias current is measured using a 10 kΩ resistor by pin VDDS connected to pin NC. The setpoint is 200 μA which is equivalent to a voltage drop of 2 V.

CFGIBN    Adr 0x01, bit 7:4			
Code k	$IBN \sim \frac{31}{39-k}$	Code k	$IBN \sim \frac{31}{39-k}$
0x0	79 %	0x8	100 %
0x1	81 %	0x9	103 %
0x2	84 %	0xA	107 %
0x3	86 %	0xB	111 %
0x4	88 %	0xC	115 %
0x5	91 %	0xD	119 %
0x6	94 %	0xE	124 %
0x7	97 %	0xF	129 %

Table 11: Bias Current

**Temperature Sensor**

The temperature monitoring is calibrated in operating mode *Calibration 3*.

To set the required warning temperature  $T_2$  the temperature sensor voltage  $VT_s$  at which the warning message is generated is first determined. To this end a voltage ramp from VDDS towards GNDS is applied to pin PA until pin ERR displays the warning message. The following settings are required here: EMASKA = 0x20, EMTD = 0x00 and EPH = 0x00.

The signal at ERR first switches from tristate to low (on reaching the warning threshold  $VT_s$ ) and then from low to tristate (on overshooting the internal hysteresis

which is not relevant to calibration). To avoid confusion a clear change of state (from low to high) must be generated with the help of an external pull-up resistor at pin ERR.

*Example:  $VT_s(T_1)$  is ca. 650 mV, measured from VDDS versus PA, with  $T_1 = 25 \text{ °C}$ ;*

The necessary reference voltage  $VT_{th}(T_1)$  is then calculated. The required warning temperature  $T_2$ , temperature coefficients TCs and TCth (see Electrical Characteristics, Section E) and measurement value  $VT_s(T_1)$  are entered into this calculation:

$$VT_{th}(T_1) = \frac{VT_s(T_1) + TC_s \cdot (T_2 - T_1)}{1 + TC_{th} \cdot (T_2 - T_1)}$$

*Example: For  $T_2 = T_1 + 100 \text{ K}$   $VT_{th}(T_1)$  must be programmed to 443 mV.*

Reference voltage  $VT_{th}(T_1)$  is provided for a high impedance measurement (10 MΩ) at output pin NA and must be set by programming CFGTA(3:0) to the calculated value.

CFGTA    Adr 0x01, bit 3:0			
Code k	$VT_{th} \sim \frac{65+3k}{65}$	Code k	$VT_{th} \sim \frac{65+3k}{65}$
0x0	100 %	0x8	137 %
0x1	105 %	0x9	142 %
0x2	109 %	0xA	146 %
0x3	114 %	0xB	151 %
0x4	118 %	0xC	155 %
0x5	123 %	0xD	160 %
0x6	128 %	0xE	165 %
0x7	132 %	0xF	169 %

Table 12: Temperature Monitoring

## OPERATING MODES

iC-MQ has various modes of operation, for which the functions of outputs PA, NA, PB, NB, PZ, NZ and ERR are altered.

Two operating modes can be selected for the output of the angle position in normal operation. *Mode 191/193* provides control signals for devices compatible with 74HC191 or 74HC193, whereas in *Mode ABZ* the angle position is output incrementally as an en-

coder quadrature signal with a zero pulse. Only in these modes are the line drivers and the reverse polarity protection feature active.

In order to condition the input signals and to calibrate and test iC-MQ *Calibration* and *Test* modes are available. Digital and analog test signals are provided; the latter must always be measured at high load impedance.

MODE(3:0)		Adr 0x02; Bit 3:0						
Code	Operating Mode	PA	NA	PB	NB	PZ	NZ	ERR
0x00	Mode ABZ	A	not(A)	B	not(B)	Z	not(Z)	ERR
0x0F	Mode 191/193	CPD	CPU	CP	nU/D	MR	nPL	ERR
0x01	Calibration 1	TANAZ(2)	VREFIZ	VREFISC	IBN	PCH0	NCH0	IERR
0x02	Calibration 2	PCH1	NCH1	PCH2	NCH2	VDC1	VDC2	
0x03	Test 3*	VPAH	VPD	—	CGUCK	IPF	V05	IERR
0x04	Test 4*	PS_out	NS_out	PC_out	NC_out	PZO	NZO	IERR
0x05	Test 5*	PSIN	NSIN	PCOS	NCOS	PZO	NZO	IERR
0x06	Test 6*	PCH1I	NCH1I	PCH2I	NCH2I	VDC1	VDC2	res.
0x07	Calibration 3	VTs	VTth	—	—	VTTFE	VTTSE	ERR
0x08	Lo-Signal	All outputs and SCL, SDA, ERR to low level						
0x09	Hi-Signal	All outputs to high level						
0x0A	Test 10*	TP	CLK6	CLK1	CLK3/8	Z <sub>In</sub>	CLK4	
0x0B	System Test*	A <sub>4</sub>	A <sub>8</sub>	B <sub>4</sub>	B <sub>8</sub>	Z <sub>In</sub>	TP1	ERR
0x0C	Test 12*	A	not(A)	B	not(B)	Z	not(Z)	ERR
0x0D	—	—	—	—	—	—	—	—
0x0E	IDDDQ Test*	All PU/PD resistors, oscillator and analog supply voltage deactivated.						
	Hints	*) Test function for iC-Haus device test only.						

Table 13: Operating Modes

### Mode ABZ

In *Mode ABZ* A/B signals are generated and output via PA, NA, PB and NB. A freely configurable zero signal is simultaneously provided at pins PZ and NZ. The differential RS422 line drivers are active; an Nx pin constantly supplies a complementary signal which is the inversion of pin Px.

### Mode 191/193

In *Mode 191/193* the output pins provide control signals for counter devices compatible with 74HC191 or 74HC193 according to the following table. The driving capability (SIK) and the slew rate (SSR) of the output drivers must be selected so that the clock pulses can be output with a low pulse of typically 50 ns (see Electrical Characteristics, 511).

Mode 191/193		
Pin	Signal	Description
PA	CPD	Clock Down Pulse
NA	CPU	Clock Up Pulse
PB	CP	Clock Pulse
NB	nU/D	Count Direction (0: up, 1: down)
PZ	MR	Asynch. Master Reset (active high) Signal is '1' if index position is reached, otherwise '0'.
NZ	nPL	Asynch. Parallel Load Input (active low) / Reset (active low) Signal is '0' if index position is reached, otherwise '1'.

Table 14: Operating mode for counter devices compatible with 74HC191 or 74HC193.

### Calibration 1, 2, 3

These modes are used to condition the input signals and calibrate iC-MQ. In mode *Calibration 1* the user can measure the IBN bias current and the zero channel analog signals are available following signal conditioning (PCH0 and NCH0).

In mode *Calibration 2* the conditioned sine and cosine signals are output (PCH1, NCH1, PCH2 and NCH2). In addition intermediate potential VDC1 is provided for compensating circuit CH1, as is intermediate potential VDC2 for CH2 (for a description of the calibration process, see page 19).

In mode *Calibration 3* the internal temperature monitoring signals are provided. Calibration of the bias current source and temperature monitoring is described on page 14 and calibration of the zero channel on page 22.

### TEST 6

The input voltages at pins X3 to X6 can be checked in mode *Test 6*. The following settings are required here:

- GF1 = 0x0
- GF2 = 0x0
- Byte 0x05, bit 3:0 = '0000'
- Byte 0x0F, bit 3 = '1'
- Byte 0x0F, bit 4 = '0'

### System Test

This mode enables the signal conditioning to be adjusted using compared sine and cosine signals. To this end at a resolution of 8 the interpolator generates

a switchpoint every 45 degrees. The objective of the calibration procedure is a pulse duty cycle of exactly 50% respectively for A<sub>4</sub>, B<sub>4</sub> und A<sub>8</sub>, B<sub>8</sub>. The following settings are required for mode *System Test*:

- MODE = 0x0B
- SELRES = 0x1B0
- SELHYS = 0xF
- CFGABZ(7:4) = '0000'

System Test		
Pin	Signal	Description
PA	A <sub>4</sub>	Offset CH1
NA	A <sub>8</sub>	Phase deviation from 90° between CH1 and CH2
PB	B <sub>4</sub>	Offset CH2
NB	B <sub>8</sub>	Amplitude deviation between CH1 and CH2
PZ	Z <sub>in</sub>	Digital zero signal, unmasked
NZ	TP1	Verification of line count (pulses) between two zero pulses Low signal: verification running (state after power on reset) High signal: verification finished An error messaging at ERR is valid after the second zero signal (enable required).

Table 15: Digital Calibration Signals

**INPUT CONFIGURATION**

All input stages are configured as instrumentation amplifiers and thus directly suitable for differential input signals. Referenced input signals can be processed; input X2 can be configured as a reference input. Both current and voltage signals can be processed, selected using RIN12 and RIN0.

INMODE	
Code	Function
0	Differential input signals
1	Single-ended input signals *
Note	* Input X2 is reference for all inputs.

Table 16: Input Signal Mode

**Current Signals**

In I Mode an input resistor Rin() becomes active at each input pin, converting the current signal into a voltage signal. Input resistance Rin() consists of a pad wiring resistor and resistor Rui() which is linked to the adjustable bias voltage source VREFin(). BIASEX must be set to '00'. The table besides shows the possible selections, with Rin() giving the typical resulting input resistance (see Electrical Characteristics for tolerances). The input resistor should be set in such a way that intermediate potentials VDC1 and VDC2 lie between 125 mV and 250 mV (verifiable in mode Calibration 2).

**Voltage Signals**

In V mode an optional voltage divider can be selected which reduces unacceptably large input amplitudes to ca. 25%. The circuitry is equivalent to the resistor chain in I mode; the pad wiring resistor is considerably larger here, however. For sensors whose offset calibration is to be proportional to an external DC voltage source the reference source can be selected using BIASEX; for all other sensors BIASEX should be set to '00'.

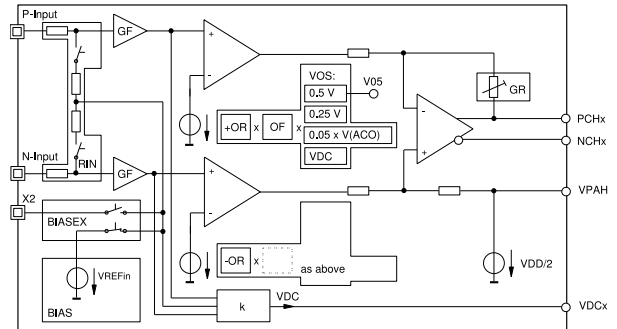

Figure 2: Signal Conditioning

RIN12		RIN0	
Adr 0x0E, bit 3:0		Adr 0x13, bit 3:0	
Code	Nominal Rin()	Internal Rui()	I/V Mode
-000	1.7 kΩ	1.6 kΩ	current input
-010	2.5 kΩ	2.3 kΩ	current input
-100	3.5 kΩ	3.2 kΩ	current input
-110	4.9 kΩ	4.6 kΩ	current input
1-1	20 kΩ	5 kΩ	voltage input
0-1	high impedance	1 MΩ	voltage input

Table 17: I/V Mode and Input Resistance

BIAS12		BIAS0	
Adr 0x0E, bit 6		Adr 0x13, bit 6	
Code	VREFin()	Type of sensor	
0	2.5 V (3 V*)	Lowside sink current (I Mode)	
1	1.5 V (2 V*)	Highside current source (I Mode)	
Note	Not valid with BIASEX=11.		

Table 18: Reference Voltage  
\*) For version iC-MQ 3

BIASEX		
Adr 0x0D, bit 7:6		
Code	VREFin()	Signal at X2
00*	1.5/2.5 V (internal)	Neg. Zero Signal (Index -), input
10	1.5/2.5 V (internal)	Ref. Voltage VREFin12, output
11	external**	Ref. Voltage VREFin, input
Note	*) Fixed setting of version iC-MQ 3 **) The voltage applied externally to X2 is reference for all inputs.	

Table 19: Input Reference Selection

**SIGNAL PATH MULTIPLEXING**

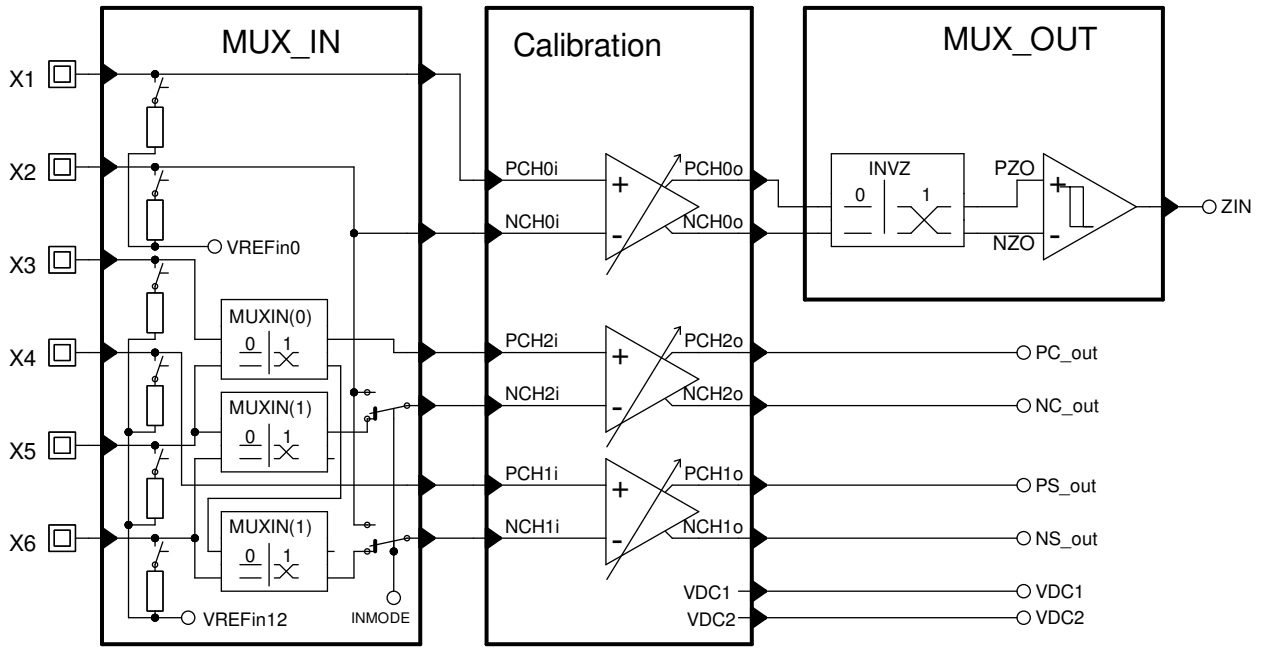

Figure 3: Principle Of Multiplexer Function

The signals for index channel CH0 are connected up to pins X1 and X2. Pins X3 to X6 are allocated to internal channels CH1 and CH2 via MUXIN. INMODE can be activated for referenced input signals; this then selects X2 as the reference signal input. For output purposes INVZ allows the index signal phase to be inverted for channel CH0.

<b>MUXIN</b> Adr 0x03, bit 1:0				
Code	PCH1i	NCH1i	PCH2i	NCH2i
00	X4	X2	X3	X2
01	not permitted			
10	not permitted			
11	X4	X2	X5	X2

Table 21: Input Multiplexer for INMODE = 1

<b>MUXIN</b> Adr 0x03, bit 1:0				
Code	PCH1i	NCH1i	PCH2i	NCH2i
00	X4	X6	X3	X5
01	not permitted			
10	X4	X5	X3	X6
11	X4	X3	X5	X6

Table 20: Input Multiplexer for INMODE = 0

<b>INVZ</b> Adr 0x03, bit 3		
Code	PZO	NZO
0	PCH0o	NCH0o
1	NCH0o	PCH0o

Table 22: Index Signal Inversion

**SIGNAL CONDITIONING CH1, CH2**

The analog voltage signals necessary for the calibration of the sine signals can be measured in operation mode *Calibration 2*. Alternatively, characteristic digital test signals are also available for offset, amplitude and phase errors in operating mode *System Test*.

**Gain Settings**

The gain is set in four steps:

1. The sensor supply controller is shut down and the constant current source for the ACO output set to a suitable output current (register ADJ; current value close to the later operating point).
2. The coarse gain is selected so that differential signal amplitudes of ca. 1 Vpp are produced internally (signal Px versus Nx, see Figure).
3. Using fine gain factor GF2 the CH2 signal amplitude is then adjusted to 1 Vpp.
4. The CH1 signal amplitude can then be adjusted to the CH2 signal amplitude via fine gain factor GF1. This results in a total gain of GR12 \* GFi for differential input signals.

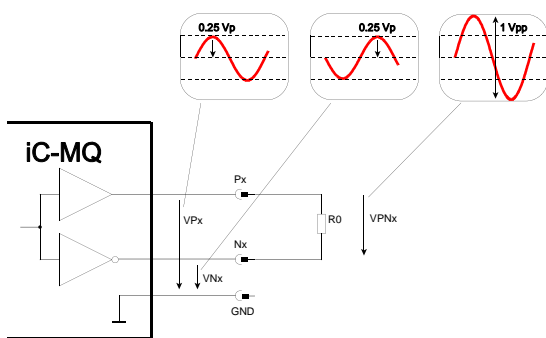

Figure 4: Definition of 1 Vpp signal. Termination R0 must be high-ohmic during all *Test* and *Calibration* modes.

GR12 ADr 0x04, bit 2:0		
Code	Range RIN12=0x9	Range RIN12≠0x9
0x0	0.5	2.0
0x1	1.0	4.1
0x2	1.3	5.3
0x3	1.7	6.7
0x4	2.2	8.7
0x5	2.6	10.5
0x6	3.3	13.2
0x7	4.0	16.0

Table 23: Gain Range CH1, CH2

GF2 ADr 0x04, bit 7:3	
Code	Factor
0x00	1.00
0x01	1.06
...	$6.25^{\frac{GF2}{31}}$
0x1F	6.25

Table 24: Fine Gain Factor CH2

GF1 ADr 0x06, bit 2:0, ADr 0x05, bit 7:4	
Code	Factor
0x00	1.0
0x01	1.015
...	$6.25^{\frac{GF1}{124}}$
0x7F	6.53

Table 25: Fine Gain Factor CH1

### Offset Calibration CH1, CH2

In order to calibrate the offset the reference source must first be selected using VOS12. Two fixed voltages and two dependent sources are available for this purpose. The fixed voltage sources should be selected for external sensors which provide stable, self-regulating signals.

So that photosensors can be operated in optical encoders iC-MQ tracks changes in offset voltages via the signal-dependent source VDC when used in conjunction with the controlled sensor current source for LED supply (pin ACO). The VDC potential automatically tracks higher DC photocurrents. To this end intermediate potentials VDC1 and VDC2 must be adjusted to a minimal AC ripple using the selectable k factor (this calibration must be repeated when the gain setting is altered). The ideal DC voltage level of 0.125 V to 0.25 V is selected via input resistor  $R_{ui}$ .

The feedback of pin voltage  $V(ACO)$  fulfills the same task as source VDC when MR bridge sensors are supplied by the controlled sensor current source. In this instance the VDC sources do not need adjusting.

VOS12		Adr 0x0E, bit 5:4
Code	Source	
0x0	$0.05 \cdot V(ACO)$	
0x1	0.5 V	
0x2	0.25 V	
0x3	VDC (VDC1 for CH1, VDC2 for CH2)	

Table 26: Offset Reference Source CH1, CH2

VDC1		Adr 0x07, bit 4:0; Adr 0x06, bit 7
VDC2		Adr 0x08, bit 6:1
Code	$VDC = k \cdot V_{Pi} + (1 - k) \cdot V_{Ni}$	
0x00	$k = 0.33$	
0x01	$k = 0.335$	
...	$k = 0.33 + VDC_i \cdot 0.0052$	
0x3F	$k = 0.66$	

Table 27: Intermediate Voltages CH1, CH2

The offset calibration range for CH1 and CH2 is dependent on the selected VOS12 source and is set using OR1 and OR2. Both sine and cosine signals are then calibrated using factors OF1 and OF2. The calibration target is reached when the DC fraction of the differential signals PCHi versus NCHi is zero.

OR1		Adr 0x09, bit 0; Adr 0x08, bit 7
OR2		Adr 0x0A, bit 5:4
Code	Range	
0x0	x2	
0x1	x4	
0x2	x12	
0x3	x24	

Table 28: Offset Range CH1, CH2

OF1		Adr 0xA, bit 3:0; Adr 0x9, bit 7:4	
OF2		Adr 0xC, bit 0; Adr 0xB, bit 7:1	
Code	Factor	Code	Factor
0x00	0	0x80	0
0x01	0.0079	0x81	-0.0079
...	$0.0079 \cdot OF_i$	...	$-0.0079 \cdot OF_i$
0x7F	1	0xFF	-1

Table 29: Offset Factors CH1, CH2

### Phase Correction CH1 vs. CH2

The phase shift between CH1 and CH2 can be adjusted using parameter PH12. Following this the calibration of the amplitude compensation, intermediate potentials and offset voltages may have to be corrected.

PH12		Adr 0xD, bit 2:0; Adr 0xC, bit 7:5	
Code	Correction angle	Code	Correction angle
0x00	+0	0x20	-0
0x01	+0.63	0x21	-0.63
...	$+0.63 \cdot PH_{12}$	...	$-0.63 \cdot PH_{12}$
0x1F	+20.2	0x3F	-20.2

Table 30: Phase Correction CH1 vs. CH2

**Adjustment Of Signal Conditioning:  
Typical Procedure**

Step	Operting Mode and Parameter	Calibration and Signal
1.		<p>Presets GF1= 0x40, VDC1= 0x20, OF1= 0x0, GF2= 0x10, VDC2= 0x20, OF2= 0x0</p> <p>Example: LED current approx. 6.25 mA ADJ(8)= 1 (constant current source), ADJ(6:5)= 11 (range 50 mA), ADJ(4:0)= 0x04 (value 12.5)</p>
2.	<i>Calibration 2</i>	<p>Calibration of Channel 1:</p> <p>Parameter GR12: Adjust diff. signal at PA vs. NA to approx. 1 Vpp amplitude Parameter GF1: Adjust diff. signal at PA vs. NA to exactly 1 Vpp amplitude Parameter VDC1: Minimization of VDC1 AC fraction at output PZ (ripple &lt; 10 mVpeak) Parameter OR1, OF1: Calibration of DC fraction to zero for diff. signal PA vs. NA (&lt; 5 mVdc)</p>
3.	<i>Calibration 2</i>	<p>Calibration of Channel 2:</p> <p>Parameter GF2: Adjust diff. signal at PB vs. NB to exactly 1 Vpp amplitude Parameter VDC2: Minimization of VDC2 AC fraction at ouput NZ (ripple &lt; 10 mVpeak) Parameter OR2, OF2: Calibration of DC fraction to zero for diff. signal PB vs. NB (&lt; 5 mVdc)</p>
4.	<i>System Test</i>	<p>1. Iteration, Calibration of Channel 1 vs. Channel 2:</p> <p>Parameter OF1: Adjust duty ratio of A<sub>4</sub> at PA to 50 % Parameter OF2: Adjust duty ratio of B<sub>4</sub> at PB to 50 % Parameter PH12: Adjust duty ratio of A<sub>8</sub> at NA to 50 % Parameter GF1: Adjust duty ratio of B<sub>8</sub> at NB to 50 %</p>
5.	<i>Calibration 2</i>	<p>Repeated Adjustment of Intermediate Voltages, VDC1 and VDC2:</p> <p>Parameter VDC1: Minimization of VDC1 AC fraction at ouput PZ Parameter VDC2: Minimization of VDC2 AC fraction at ouput NZ</p>
6.	<i>System Test</i>	<p>2. Iteration, Calibration of Channel 1 vs. Channel 2:</p> <p>Parameter OF1: Adjust duty ratio of A<sub>4</sub> at PA to 50 % Parameter OF2: Adjust duty ratio of B<sub>4</sub> at PB to 50 % Parameter PH12: Adjust duty ratio of A<sub>8</sub> at NA to 50 % Parameter GF1: Adjust duty ratio of B<sub>8</sub> at NB to 50 %</p>

Table 31: Adjustment Of Signal Conditioning

**SIGNAL CONDITIONING CH0**

The voltage signals needed to calibrate the zero channel are available in mode *Calibration 1*. The relative phase position of the ungated zero signal  $Z_{in}$  compared to A and B can be determined in mode *System Test*.

**Gain Settings CH0**

Parallel to the conditioning process for the CH1 and CH2 signals the CH0 gain is also set in the following steps:

1. The sensor supply controller is shut down and the constant current source for the ACO output set to the same output current as in the calibration of CH1 and CH2 (register ADJ; current value close to the later operating point).
2. The coarse gain is selected so that a differential signal amplitude of ca. 1 Vpp is produced internally (signal PCHi versus NCHi).
3. GF0 then permits fine gain adjustment to 1 Vpp. The total gain is accrued from GR0 x GF0.

<b>GR0</b> Adr 0x11, bit 2:0		
Code	Range RIN0 = 0x9	Range RIN0 ≠ 0x9
0x0	0.5	2.0
0x1	1.0	4.1
0x2	1.3	5.3
0x3	1.7	6.7
0x4	2.2	8.7
0x5	2.6	10.5
0x6	3.3	13.2
0x7	4.0	16.0

Table 32: Gain Range CH0

<b>GF0</b> Adr 0x11, bit 7:3	
Code	Factor
0x00	1.00
0x01	1.06
...	$6.25 \frac{GF0}{31}$
0x1F	6.25

Table 33: Fine Gain Factor CH0

**Offset Calibration CH0**

To calibrate the offset the reference source must first be selected using VOS0 (see Offset Calibration CH1 and CH2 for further information). For the CH0 path the dependent source VDC is identical to source VDC1.

<b>VOS0</b> Adr 0x13, bit 5:4	
Code	Source
0x0	$0.05 \cdot V(ACO)$
0x1	0.5 V
0x2	0.25 V
0x3	VDC (i.e. VDC1)

Table 34: Offset Reference Source CH0

<b>OR0</b> Adr 0x12, bit 1:0	
Code	Range
0x0	x2
0x1	x4
0x2	x12
0x3	x24

Table 35: Offset Range CH0

<b>OF0</b> Adr 0x12, bit 7:2			
Code	Factor	Code	Factor
0x00	0	0x20	0
0x01	0.0322	0x21	-0.0322
...	$0.0322 \cdot OF0$	...	$-0.0322 \cdot OF0$
0x1F	1	0x3F	-1

Table 36: Offset Factor CH0

**SIGNAL LEVEL CONTROLLER**

Via the controlled sensor current source (pin ACO) iC-MQ can keep the input signals for the internal sine-to-digital converter constant regardless of temperature and aging effects by tracking the sensor supply. Both the controller operating range and input signal amplitude for the controller are monitored and can be enabled for error messaging. A constant current source can be selected for the ACO output when setting the signal conditioning; the current range for the highside current source is adjusted using ADJ(6:5).

<b>ADJ (8:7)</b> Adr 0x10, bit 7:6	
Code	Function
00	Square control mode
01	Sum control mode
10	Constant current source
11	Not permitted

Table 37: Controller Operating Modes

<b>ADJ (6:5)</b> Adr 0x10, bit 5:4	
Code	Function
00	5 mA - Range
01	10 mA - Range
10	25 mA - Range
11	50 mA - Range

Table 38: Output Current Range (applies for control modes and constant current source)

In operation with the active square control mode ADJ(4:0) sets the internal signal amplitudes according

to the relation  $(PCH1-NCH1)^2 + (PCH2-NCH2)^2$ ; these should be set to 0.25 Vp.

<b>ADJ (4:0)</b> Adr 0x10, bit 3:0; Adr 0x0F, bit 7	
Code	Setpoint
0x00	3.125 % * I <sub>max</sub>
...	...
0x1F	100 % * I <sub>max</sub>

Table 39: Current Source Setpoint

<b>ADJ (4:0)</b> Adr 0x10, bit 3:0; Adr 0x0F, bit 7	
Code	Function
0x00	60 %
0x01	61 %
...	...
0x19	98 %
0x1A	101 %
0x1B	104 %
...	...
0x1F	120 %

Table 40: Internal Sin/Cos Signal Amplitudes for Square Control Mode

<b>ADJ (4:0)</b> Adr 0x10, bit 3:0; Adr 0x0F, bit 7	
Code	Function
0x00	VDC1+VDC2 = 224 mV
...	...
0x1F	VDC1+VDC2 = 472 mV

Table 41: Internal DC Setpoint for Sum Control Mode

**SINE-TO-DIGITAL CONVERSION**

<b>SELRES</b> Adr 0x1C, bit 6:0; Adr 0x1B, bit 7:0			
Value	STEP Angle Steps Per Period	IPF Interpolation Factor	fin()max Permissible Input Frequency (MTD=0x8)
0x00E0	4	1	200 kHz
0x01B0	8	2	200 kHz
0x02A0	12	3	200 kHz
0x0398	16	4	200 kHz
0x0414	20	5	200 kHz
0x0590	24	6	166 kHz
0x078C	32	8	125 kHz
0x090A	40	10	100 kHz
0x0B88	48	12	83 kHz
0x0F86	64	16	62.5 kHz
0x1305	80	20	50 kHz
0x1784	96	24	40 kHz
0x1804	100	25	40 kHz
0x1F83	128	32	30 kHz
0x2F82	192	48	20 kHz
0x3102	200	50	20 kHz
0x5F81	384	96	10 kHz
0x6301	400	100	10 kHz

Table 42: Converter Resolution

iC-MQ's converter resolution can be set using SELRES. For a resolution of 4, four angle steps per input signal period are generated so that the switching frequency at the A and B output matches the sine frequency at the input.

The programmable converter hysteresis is determined by SELHYS. It is set in multiples of the increment size and may have a maximum of 45° of the input signal period.

<b>SELHYS</b> Adr 0x1D, bit 3:0	
Code	Function
0x0	Device test only
0x1	1 increment ( $\approx 0.9^\circ$ )
0x2	2 increments ( $\approx 1.8^\circ$ )
0x3-0xD	3-13 increments ( $\approx 2.7^\circ$ - $11.7^\circ$ )
0xE	SELRES(6:1) increments (0.5 LSB)
0xF*	SELRES(6:0) increments
Notes	*) Not permissible with SELRES = 0x00E0

Table 43: Converter Hysteresis

**OUTPUT SETTINGS AND ZERO SIGNAL**

The set interpolation factor IPF determines the number of A/B signal cycles generated internally which are counted via register POS to enable the positioning of the zero pulse. At a sine/cosine phase angle of zero degree the A/B cycle count starts at POS = 0, and the highest cycle count is reached when POS<sub>max</sub> = IPF-1. The internal A/B signal cycle adheres to the following pattern:

A	1	1	0	0
B	1	0	0	1

Table 44: Internal A/B Signal Cycle

Inversions and reversals can be selected for the output of the A/B/Z signals and any logic combination for the output of the zero signal. The output logic pairs parameters CFGABZ in accordance with the table below:

CFGABZ		Adr 0x19, bit 7:0
Bit	Function and Description	
7	Output inversion for channel A: PA<->NA PA = P1i xor CFGABZ(7)	
6	Output inversion for channel B: PB<->NB PB = P2i xor CFGABZ(6)	
5	Output inversion for index channel: PZ<->NZ PZ = P0i xor CFGABZ(5)	
4	Exchange of A/B signal assignment 0: P1i = A, P2i = B 1: P1i = B, P2i = A	
Zero Signal Logic CFGABZ(3:0)		
3	Enable for A = 1, B = 1	
2	Enable for A = 1, B = 0	
1	Enable for A = 0, B = 0	
0	Enable for A = 0, B = 1	

Table 45: Output Logic

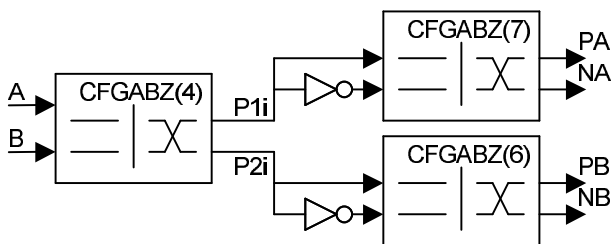

Figure 5: Signal Path from A and B to PA/NA and PB/NB

**Zero Signal Generation**

The generation of the zero signal is dependant on the internal enable signal Z<sub>in</sub> which is produced by comparing the processed X1 and X2 input signals. The offset calibration of CH0 influences the width of the enable signal so that the correct position of Z<sub>in</sub> should be checked before the zero signal logic is configured. In Mode ABZ this is possible at the error signal output (pin ERR; required settings are EMASKA = 0x010 and EMTD = 0x0).

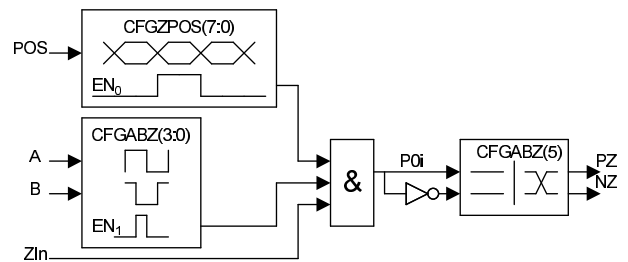

Figure 6: Signal path from Z<sub>in</sub> to PZ/NZ

The positioning of the zero signal by CFGZPOS is relative to the internal A/B cycle count POS. A cycle must be selected across which enable signal Z<sub>in</sub> is centered as far as is possible. For cycle counts which cannot be achieved due to a smaller interpolation factor no zero signal is generated.

CFGZPOS		Adr 0x1A, bit 7:0
Bit	Description	
7	Mask Enable (zero signal position determined by POS)	
(6:0)	POS = A/B cycle count nI (releases zero signal output)	

Table 46: Zero Signal Positioning

ENZFF		Adr 0x02, bit 4
Bit	Description	
0	Zero signal output with state change of P0i	
1	Version iC-MQ 3: not permitted Version iC-MQ X1: Zero signal output synchronized with A/B signal	

Table 47: Zero Signal Synchronization

**Description Of CFGABZ Setup**

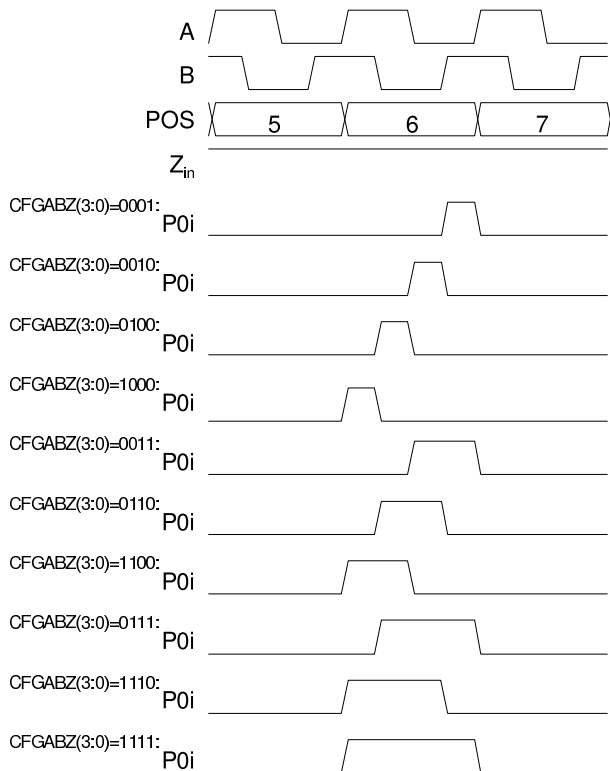

Figure 7: Function of zero signal logic CF-GABZ(3:0) (Example for CFGZPOS(7)=1, CFGZPOS(6:0)=0x6)

**Setup Example 1**

Incremental ABZ output with a zero signal of 180° synchronous with the A signal at PA:  
CFGABZ = "0000 1100"

**Setup Example 2**

Incremental ABZ output with a zero signal of 270° which can be synchronized externally with a 90° zero pulse for PA = 1 und PB = 1:  
CFGABZ = "1100 0111"

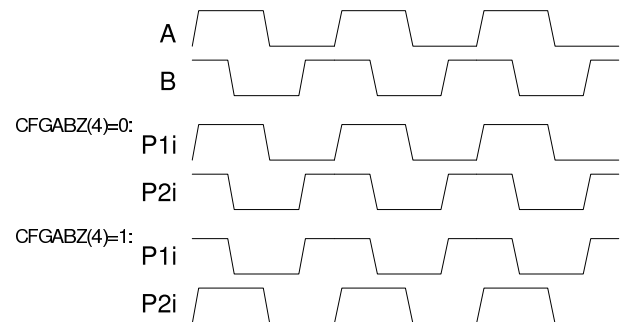

Figure 8: Function of CFGABZ(4)

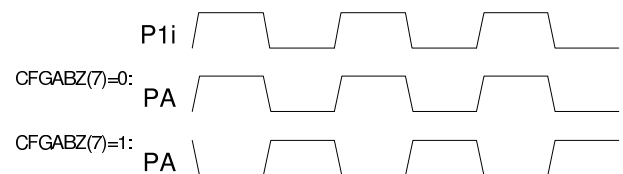

Figure 9: Function of CFGABZ(7)

### Output Driver Configuration

The output drivers can be used as push-pull, lowside or highside drivers; the mode of operation is determined by TRIHL(1:0).

In order to avoid steep edges when transmitting via short wires the slew rate can be set using SSR to suit the length of the cable. This can result in a limiting of the maximum permissible output frequency if at the same time the RS422 specification is to be adhered to (for example, to 300 kHz at a slew rate of 300 ns; the tolerances in Electrical Characteristics, numbers 506/507, must be observed).

The driver output short-circuit current can be set by SIK and can be minimized when connecting to logic or to an external 24 V line driver. If the outputs are used as RS422-compatible 5 V drivers, it is recommended that SIK = 11 to keep the power dissipation of iC-MQ low.

(Version iC-MQ 3: After startup the outputs are initially configured as lowside drivers with a small short-circuit current (SIK = 00).)

TRIHL		Adr 0x1E, bit 1:0
Code	Function	
00	Push-pull operation	
01	Highside driver mode (P channel open drain)	
10	Lowside driver mode (N channel open drain)	
11	Not permitted	

Table 48: Output Drive Mode

SSR		Adr 0x1E, bit 3:2
Code	Function	
00	Nominal value 12 ns	
01	Nominal value 25 ns	
10	Nominal value 80 ns	
11	Nominal value 220 ns	
Note	See Elec. Char. Nos. 506/507	

Table 49: Output Slew Rate

SIK		Adr 0x1E, bit 5:4
Code	Function	
00	typ. 2 mA, linking logic or driver ICs	
01	typ. 8 mA	
10	typ. 40 mA	
11	typ. 100 mA, recommended for RS422	
Note	See Elec. Char. Nos. 503/504	

Table 50: Output Short-Circuit Current

### Minimum Phase Distance

The minimum phase distance for the A/B and Z output signals can be preselected using MTD(3:0). This setting limits the maximum possible output frequency for safe transmission to counters which cannot debounce spikes or only permit a low input frequency.

When preselecting the minimum edge distance the configuration of the RS422 output drivers (with regard to the driver current and slew rate) and the length of cable used must be taken into account.

MTD		Adr 0x1D, bit 7:4
Code	Function	
0x8	200 ns	
0x9	400 ns	
0xA	600 ns	
0xB	800 ns	
0xC	1.0 μs	
0xD	1.2 μs	
0xE	1.4 μs	
0xF	1.6 μs	
Note	Codes 0x0 to 0x7 are not permitted. All timing specifications are nominal values, see Elec. Char. No. 512 for tolerances.	

Table 51: Minimum Phase Distance

**ERROR MONITORING AND ALARM OUTPUT**

iC-MQ monitors the input signals, the internal interpolator and the sensor supply controller via which the input signal levels are stabilized. If the sensor supply tracking unit reaches its control limits this can be interpreted as an end-of-life message, for example.

Three separate error masks stipulate whether error events are signaled as an alarm via the current-limited open drain I/O pin ERR (mask EMASKA), whether they cause the RS422 line drivers to shutdown or not (mask EMASKO) or whether they are stored in the EEPROM (mask EMASKE).

The display logic (via EPH) and the minimum alarm indication time (via EMTD) can be set for I/O pin ERR; an internal pull-up current source can be switched in via EPU. ERR pin also has an input function for switching iC-MQ to test mode (see page 30) and for the acceptance of a system error message in normal operation (only for EPH = 0).

EPH		Adr 0x15, bit 2	
Code		Pin	Logic
0		Low	on error (otherwise Z)
1		Z	on error (otherwise low)

Table 52: Alarm Input/Output Logic

EMTD				Adr 0x15, bit 5:3			
Code	Indication Time	Code	Indication Time	Code	Indication Time	Code	Indication Time
0x0	0 ms	0x4	50 ms	0x5	62.5 ms	0x6	75 ms
0x1	12.5 ms	0x7	87.5 ms				
0x2	25 ms						
0x3	37.5 ms						

Table 53: Minimum Alarm Indication Time

EPU		Adr 0x17, bit 2	
Code		Function	
0		No internal pull-up active	
1		Internal 300 µA pull-up current source active	

Table 54: Pull-Up Enable for Alarm Output ERR

PDMODE		Adr 0x18, bit 6	
Code		Function	
0		Line driver active only when no errors persist	
1		Line driver reactivation only after cycling power	

Table 55: Driver Reactivation

EMASKA		Adr 0x15, bit 1:0; Adr 0x14, bit 7:0	
Bit		Error event	
9		Line count error (wrong count of sine periods between two zero pulses)	
8		Temporal tracking error (out-of-sync: position output differs from actual angle, e.g. after cycling power)	
7		Loss of tracking (excessive input frequency)	
6		Configuration error* (SDA or SCL pin error, no acknowledge signal from EEPROM or invalid check sum)	
5		Excessive temperature warning	
4		Ungated index enable signal $Z_{in}$ (compared X1/X2 inputs for CFGABZ and CFGZPOS adjustment)	
3		Control error: range at max. limit	
2		Control error: range at min. limit	
1		Signal error: clipping due to excessive input level	
0		Signal error: loss of signal (poor input level or s/c phase out of range)	
Notes		*) The line drivers remain high impedance (tristate) when cycling power.	

Table 56: Error Event Mask for Alarm Output

EMASKO		Adr 0x17, bit 1:0; Adr 0x16, bit 7:0	
Bit		Error event	
9		Line count error (wrong count of sine periods between two zero pulses)	
8		Temporal tracking error (out-of-sync: position output differs from actual angle, e.g. after cycling power)	
7		Loss of tracking (excessive input frequency)	
6		Configuration error* (ROM bit with fixed value = 1) SDA or SCL pin error, no acknowledge signal from EEPROM or invalid check sum	
5		Excessive temperature warning	
4		System error: I/O pin ERR pulled to low by an external error signal (only permitted with EPH = 0)	
3		Control error: range at max. limit	
2		Control error: range at min. limit	
1		Signal error: clipping due to excessive input level	
0		Signal error: loss of signal (poor input level or s/c phase out of range)	
Notes		*) The line drivers remain high impedance (tristate) when cycling power.	

Table 57: Error Event Mask for Driver Shutdown

### Error Protocol

Out of the errors enabled by EMASKE both the first (under ERR1) and last error (under ERR2) which occur after the iC-MQ is turned on are stored in the EEPROM. The EEPROM also has a memory area in which all occurring errors can be stored (ERR3(9:0)). Only the fact that an error has occurred can be recorded, with no information as to the time and count of appearance of that error given. Error recording can be used to statistically evaluate the causes of system failure, for example.

### Line Count Error

The line count error feature is particularly interesting for encoder systems. The disc is checked anew with each zero pulse, with the number of sine cycles counted until the next zero pulse occurs. If the direction of rotation is changed, the check is aborted. The line count is then stored under LINECNT minus 1, i.e. for a code disc with 256 lines LINECNT records a value of 255. If the counted line number does not match the number already stored in LINECNT, a line count error is set. In mode *System Test* signal TP1 indicates when the line count check is first ended.

### Temperature Monitoring

iC-MQ has an integrated temperature monitor. If the temperature warning threshold is exceeded an excessive temperature message is generated which is processed in the temperature monitor block ( $T_w$  corresponds to  $T_2$ ). The warning threshold can be signaled at pin ERR or used to shut down the line drivers (via mask EMASKO). The temperature warning is deleted when the temperature drops below  $T_w - T_{hys}$ .

If temperature  $T_{off} = T_w + \Delta T$  is exceeded the line drivers are shut down independent of EMASKO.

EMASKE	
Adr 0x18, bit 5:0; Adr 0x17, bit 7:4	
Bit	Error event
9	Line count error (wrong count of sine periods between two zero pulses)
8	—
7	Loss of tracking (excessive input frequency)
6	—
5	Excessive temperature warning
4	System error: I/O pin ERR reads low by an external error signal (only permitted with EPH=0)
3	Control error: range at max. limit
2	Control error: range at min. limit
1	Signal error: clipping due to excessive input level
0	Signal error: loss of signal (poor input level or s/c phase out of range)

Table 58: Error Event Mask for EEPROM Savings

## REVERSE POLARITY PROTECTION

iC-MQ is protected against a reversal of the supply voltage and has short-circuit-proof, error-tolerant line drivers. A defective device cable or one wrongly connected is tolerated by iC-MQ. All circuitry components which draw the monitored supply voltage from VDDS and GNDS are also protected. The following pins are also reverse polarity protected: PA, NA, PB, NB, PZ,

NZ, ERR, VDD, GND and ACO.

This is based on the condition that GNDS only receives load currents from VDDS. The maximum voltage difference between GNDS and another pin should not exceed 6V, the exception here being pin ERR (see *Test Mode* page 30).

**TEST MODE**

iC-MQ switches to test mode when a voltage greater than VTMon is applied to pin ERR (precondition: EMODE(0) = 1). In response iC-MQ transmits its setup settings as current-modulated data using error signal I/O pin ERR either directly from the RAM (for EMODE2=1) or after re-reading the EEPROM (for EMODE2=0). Should the voltage at the ERR pin fall below VTMOFF test mode is terminated and data transmission aborted.

The clock rate for the data output is determined by ENFAST. Two clock rates can be selected: 780 ns for ENFAST=1 or 3.125 μs for ENFAST=0 (see Electrical Characteristics, B12, for clock frequency and tolerances).

Data is output in Manchester code via two clock pulses per bit. To this end the lowside current source switches between a Z state (OFF = 0 mA) and an L state (ON = 2 mA).

The bit information lies in the direction of the current source switch:

- Zero bit: change of state Z → L (OFF to ON)
- One bit: Change of state L → Z (ON to OFF)

Transmission consists of a start bit (a one bit), 8 data bits and a pause interval in Z state (the timing is identical with an EEPROM access via the I<sup>2</sup>C interface).

Example: byte value = 1000 1010  
Transmission including the start bit: 1 1000 1010  
In Manchester code: LZ LZL ZLZL LZL LZL

Decoding of the data stream:

ZZZZZZ LZ LZ ZL ZL ZL LZ ZL LZ ZL ZZZZZZ  
Pause 1 1 0 0 0 1 0 1 0 Pause

EMODE		Adr 0x15, bit 7:6
Code	Function during test mode	Function following test mode
00	Normal operation	Normal operation
01	Transmission of error and OEM data*	Repeated read out of EEPROM
10	Normal operation	Repeated read out of EEPROM
11	Transmission of EEPROM contents (0x0-0x7F)	Repeated read out of EEPROM
Notes	*) Selectable address ranges: EMODE2 = 0: Addresses 0x24 to 0x7F EMODE2 = 1: Addresses 0x3B to 0x43	

Table 59: Test Mode

EMODE2		Adr 0x18, bit 7
Code	Register selection	Address range for EMODE = 01
0	EEPROM: read and send of external configuration data (DEVID is device address)	Address range 0x24-0x7F
1	RAM: send internal configuration data (ENSL = 1)	Address range 0x3B-0x43

Table 60: Register and address selection for test mode

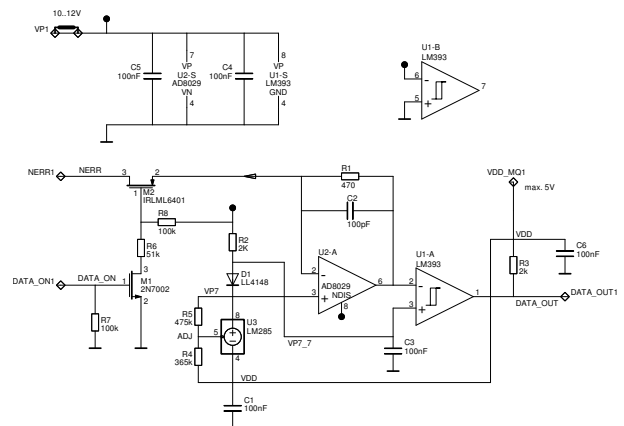

Figure 10: Example circuit for the decoding and conversion of the current-modulated signals to logic levels.

**Quick programming in the single master system**

For the purpose of signal conditioning it is possible to reprogram iC-MQ quickly. If test mode is quit and  $EMODE \neq 00$ , iC-MQ reads the configuration data in again. In place of the standard EEPROM (DEVID 0x50) an EEPROM with a different device address can be read in which can be stored under DEVID (address 0x00, bit 6:0).

In operating modes *Mode ABZ*, *System Test* and *Mode 191/193* the content of the EEPROM is read in its entirety. For other modes the address area is limited to 0x0-0x31 so that the configuration time for either calibration or IC testing is shortened.

If the setup is switched to test mode during the readin procedure, readin is aborted and only repeated once test mode has been terminated.

**Quick programming in the multimaster system**

Fast programming of iC-MQ, byte for byte, is possible with a multimaster-competent programming device. To this end the integrated I<sup>2</sup>C slave mode must be enabled by ENSL; iC-MQ then reacts to the device ID 0x55.

If no EEPROM is connected, iC-MQ automatically sets the I<sup>2</sup>C slave mode enable (after a maximum of 150 ms, see Electrical Characteristics, D11) and deactivates the digital section (ENSL = 1 and END = 0 are set). Any number of bytes can be written at any one time; the received data is accepted directly into the RAM register. The conditions given in the following table must be taken into consideration here. After programming END = 1 must be set to restart sine-to-digital conversion in the selected mode of operation.

**EXAMPLE APPLICATIONS**

Figure 11 is a circuit diagram of an optical encoder with an incremental output of quadrature signals as RS422-compatible differential signals which can be terminated by 100Ω at the controller end. By way of an alterna-

tive the magnetic encoder in Figure 12 uses magneto-resistive sensor bridges. An external overvoltage protection circuit may be realized employing TVS diodes plus a PolyFuse in the VDD line, for instance.

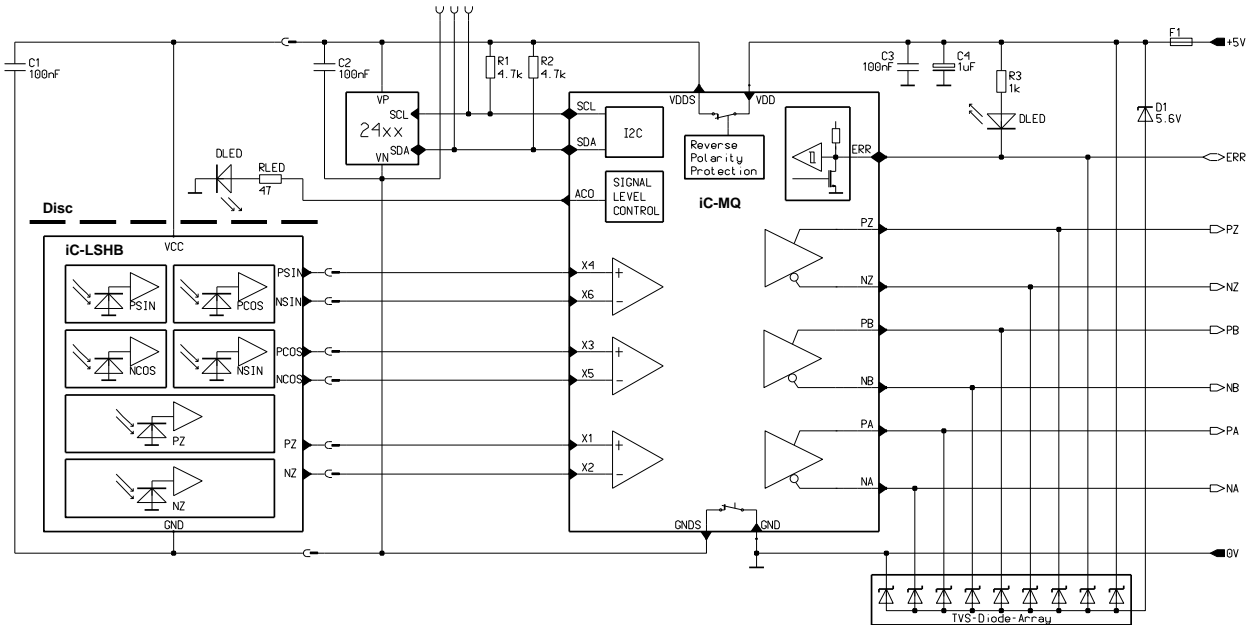

Figure 11: Example application with an optical encoder

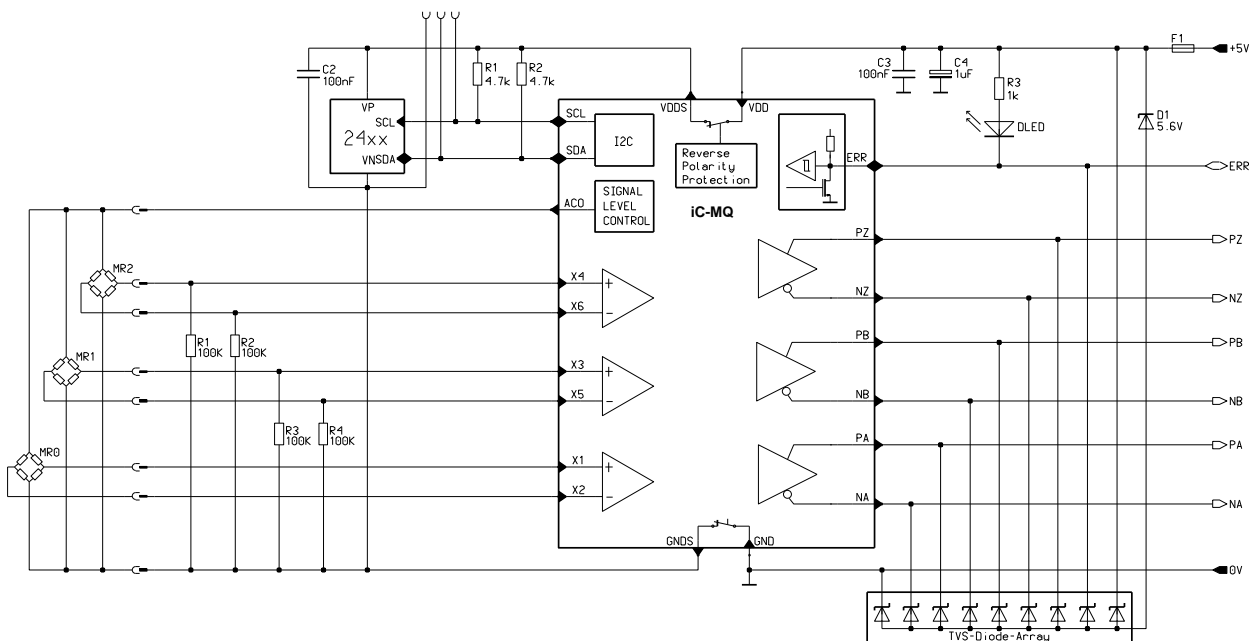

Figure 12: Example application with a magnetic encoder

When iC-MQ is used in 24 V systems, with supply voltages of 5 V to 30 V for example, it can be combined with iC-DL which acts as a line driver with an integrated line adaptation feature (Figure 13).

A reduced driving capability of iC-MQ is sufficient (SIK = 00) to operate iC-DL so that the current required is reduced at the 5 V end. If an LDO voltage regulator is selected, the circuit is suitable for a supply range of 4.5 V to 30 V without any changes having to be made.

The wiring of the iC-DL error message output (pin NER) to the PLC is not necessary if the iC-MQ error

mask is set for output shutdown (EMASKO). In the event of error the pull-down current sources ensure that a low signal is produced at the iC-DL inputs on all lines which the controller recognizes as an error. If there is an overload at the outputs, via its temperature protection unit iC-DL itself makes sure that the driver outputs are shutdown (tristate) - which the controller also classes as an error. In addition iC-MQ can transmit the overload to the error memory as a system error when information is returned to the bidirectional I/O pin ERR (as shown).

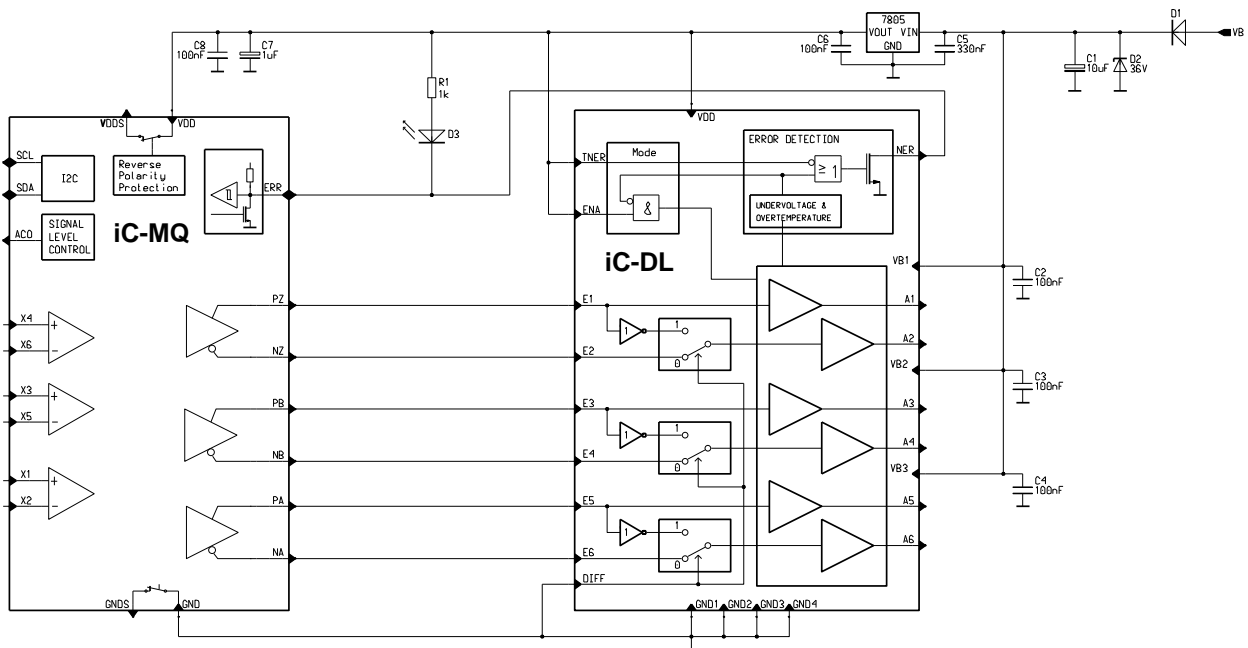

Figure 13: Example application with a 24 V line driver

## APPLICATION HINTS

### In-circuit programming of the EEPROM

Access to the EEPROM is unhindered when the iC-MQ supply voltage is kept below power down reset threshold VDDoff. In this case an EEPROM which operates at a supply voltage of 2.5V and above is required. If 3.3V are necessary to power the EEPROM, iC-MQ's supply voltage can be raised at a maximum to power on threshold VDDon; this must occur without overshooting.

The supply voltage provided by pins VDDS and GNDS can be used to power the EEPROM; shutdown only occurs with reverse polarity. Here, the load-dependent voltage drop at both switches must be taken into account; see Vs(VDDS) and Vs(GNDS) in the Electrical Characteristics, C01 and C02.

### Absolute angle accuracy and edge jitter

The precise setting of the signal conditioning unit for correction of the analog input signals is crucial to the result of interpolation; the absolute angle error obtained determines the minimum signal jitter. Here, the effect on the transition distance of the A/B output signals is not always the same but instead dependent on the absolute phase angle of the input signals. The following gives an example for an interpolation factor of 100, i.e. 400 edges per sine period.

The offset error in the cosine signal has the strongest effect on the absolute angle error at 90° and 270°; at 0° and 180° its influence on the transition distance is the most marked. With a range setting of OR1 = OR2 = 00 and VOSSC = 01 the offset error can be compensated for by an increment of 3.9 mV. If the offset has been compensated for incorrectly by one step (1 LSB), the absolute angle error would increase by ca. 0.45° and the transition distance vary by approximately +/- 0.8%. Similar conditions apply to the sine signal, with the sole difference that the maxima would be shifted by 90°.

An error in amplitude has the strongest effect on the absolute angle error at 45°, 135°, 225° and 315°; the biggest change in the transition distance can be observed at 0°, 90°, 180° and 270°. iC-MQ can compensate for the amplitude ratio in steps of 1.5% so that incorrect compensation by 1 LSB would increase the absolute angle error by ca. 0.42°. The transition distance would then vary by +/- 1.5%.

A phase error between the sine and cosine signals (a deviation in phase shift from the ideal 90°) has the most marked influence on the absolute angle error at 0°, 90°, 180° and 270°. The greatest effect on the transition distance is noted at 45°, 135°, 225° and 315°. iC-MQ's phase correction feature permits a step size of 0.64° so that incorrect compensation by 1 LSB would increase the absolute angle error by ca. 0.64°. The transition distance would then vary by +/- 1.1%.

In a perfect signal conditioning procedure it can be assumed that the residual error constitutes half a compensation step respectively. With this, in theory iC-MQ would achieve an absolute angle accuracy of ca. 0.5°, with the transition distance varying by ca. +/- 1.5%. The linearity error of the interpolator must also be taken into consideration; this increases the absolute angle error by ca. 0.12° and the variation in transition distance by 0.4%. With ideal, almost static input signals iC-MQ then obtains an absolute angle accuracy of 0.62° and a variation in transition distance of under 2%.

### Information on the demo board

The default delivery status of demo board EVAL MQ1D is such that it expects differential sine/cosine signals at inputs X3 to X6 with an amplitude of 125 mV, i.e.

$$V(X4) = 2.5 V + 0.125 V \sin(\varphi t)$$

$$V(X3) = 2.5 V - 0.125 V \sin(\varphi t)$$

$$V(X5) = 2.5 V + 0.125 V \sin(90 + \varphi t)$$

$$V(X6) = 2.5 V - 0.125 V \sin(90 + \varphi t)$$

Outputs PA, NA, PB and NB generate a differential A/B signal with an angle resolution of 4 (an interpolation factor of 1). When high sine input frequencies are applied or the resolution is increased, the minimum phase distance (MTD), short-circuit current limit (SIK) and driver slew rate (SSR) must be adjusted to meet requirements. For example, a minimum phase distance of MTD = 8 should be selected with a resolution of 200 (an interpolation factor of 50) when input frequencies of up to 20 kHz are to be applied.

**iC-MQ** PROGRAMMABLE 9-BIT  
Sin/Cos INTERPOLATION IC WITH RS422 DRIVER

preliminary



Rev B1, Page 35/36

This specification is for a newly developed product. iC-Haus therefore reserves the right to change or update, without notice, any information contained herein, design and specification; and to discontinue or limit production or distribution of any product versions. Please contact iC-Haus to ascertain the current data.

Copying – even as an excerpt – is only permitted with iC-Haus approval in writing and precise reference to source.

iC-Haus does not warrant the accuracy, completeness or timeliness of the specification on this site and does not assume liability for any errors or omissions in the materials. The data specified is intended solely for the purpose of product description. No representations or warranties, either express or implied, of merchantability, fitness for a particular purpose or of any other nature are made hereunder with respect to information/specification or the products to which information refers and no guarantee with respect to compliance to the intended use is given. In particular, this also applies to the stated possible applications or areas of applications of the product.

iC-Haus conveys no patent, copyright, mask work right or other trade mark right to this product. iC-Haus assumes no liability for any patent and/or other trade mark rights of a third party resulting from processing or handling of the product and/or any other use of the product.

As a general rule our developments, IPs, principle circuitry and range of Integrated Circuits are suitable and specifically designed for appropriate use in technical applications, such as in devices, systems and any kind of technical equipment, in so far as they do not infringe existing patent rights. In principle the range of use is limitless in a technical sense and refers to the products listed in the inventory of goods compiled for the 2008 and following export trade statistics issued annually by the Bureau of Statistics in Wiesbaden, for example, or to any product in the product catalogue published for the 2007 and following exhibitions in Hanover (Hannover-Messe).

We understand suitable application of our published designs to be state-of-the-art technology which can no longer be classed as inventive under the stipulations of patent law. Our explicit application notes are to be treated only as mere examples of the many possible and extremely advantageous uses our products can be put to.

**ORDERING INFORMATION**

Type	Package	Order Designation
iC-MQ Evaluation Board iC-MQ	TSSOP20	iC-MQ TSSOP20 iC-MQ EVAL MQ1D

For technical support, information about prices and terms of delivery please contact:

**iC-Haus GmbH**  
Am Kuemmerling 18  
D-55294 Bodenheim  
GERMANY

**Tel.: +49 (61 35) 92 92-0**  
**Fax: +49 (61 35) 92 92-192**  
**Web: <http://www.ichaus.com>**  
**E-Mail: [sales@ichaus.com](mailto:sales@ichaus.com)**

Appointed local distributors: [http://www.ichaus.de/support\\_distributors.php](http://www.ichaus.de/support_distributors.php)