

1 2 3 4 5 6

A

A

B

B

C

C

D

Spodní průměr
rádlování
12mm
Rádlo rozteč 1.2mm

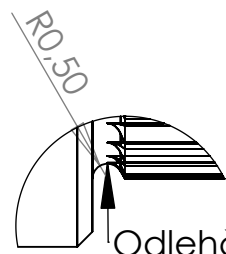
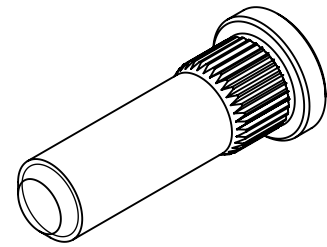
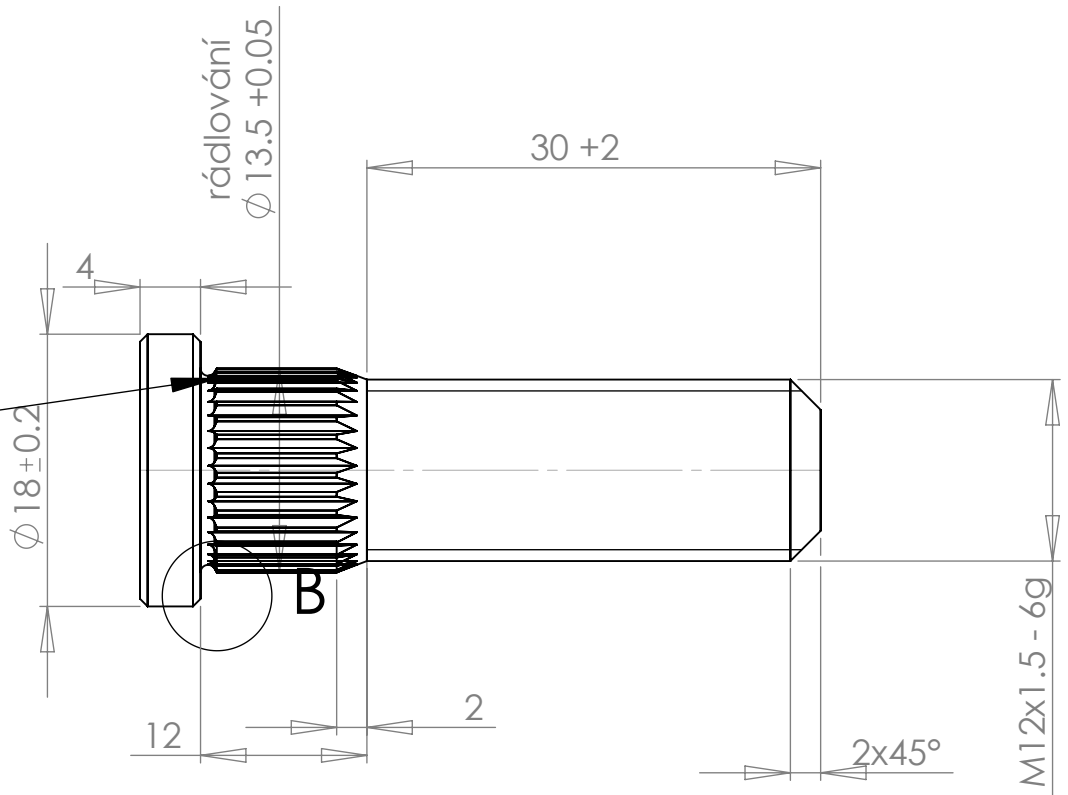

Odlehčení může
mít tvar od
soustružnického nože

DETAIL B
MĚŘÍTKO 4 : 1

UNLESS OTHERWISE SPECIFIED: DIMENSIONS ARE IN MILLIMETERS		FINISH:		DEBUR AND BREAK SHARP EDGES		DO NOT SCALE DRAWING		REVISION	
SURFACE FINISH:									
TOLERANCES:									
LINEAR:									
ANGULAR:									
	NAME	SIGNATURE	DATE			TITLE:			
DRAWN									
CHK'D									
APPV'D									
MFG									
Q.A					MATERIAL:	DWG NO.		Díl 1	
								A4	
					WEIGHT:	SCALE:2:1		SHEET 1 OF 1	