

3,2

5 x Ø 2,5 SKRZ VŠE
M3 - 6H SKRZ VŠE

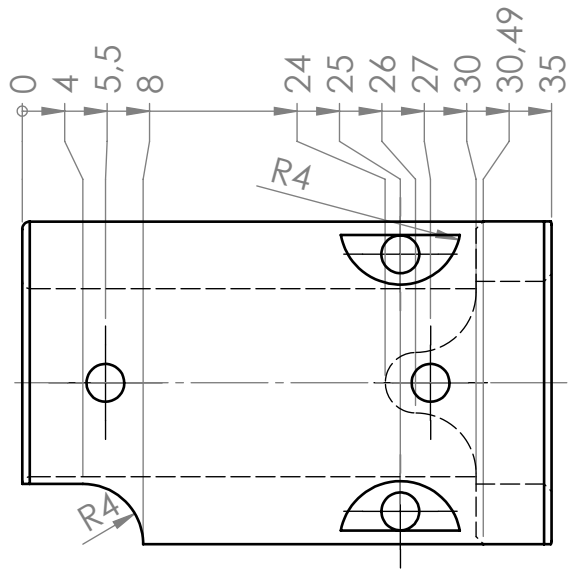
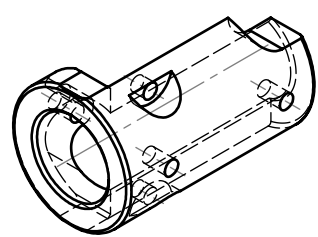
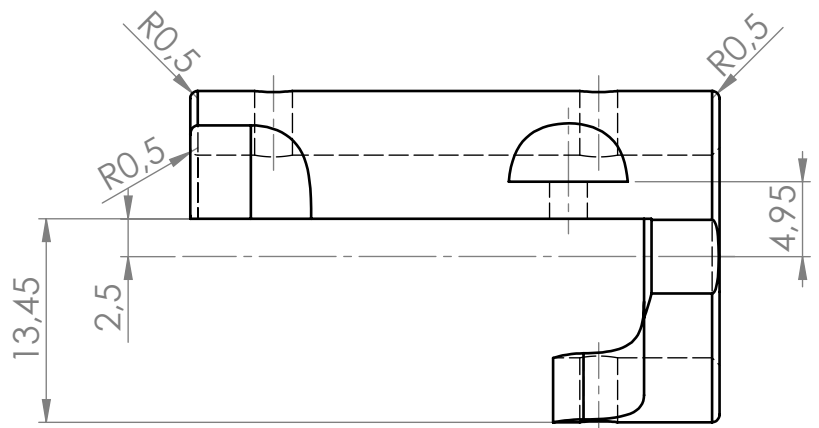
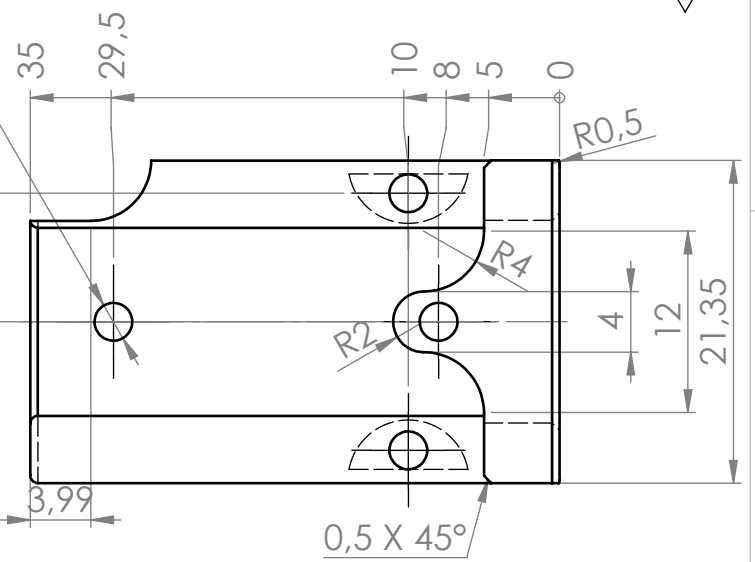
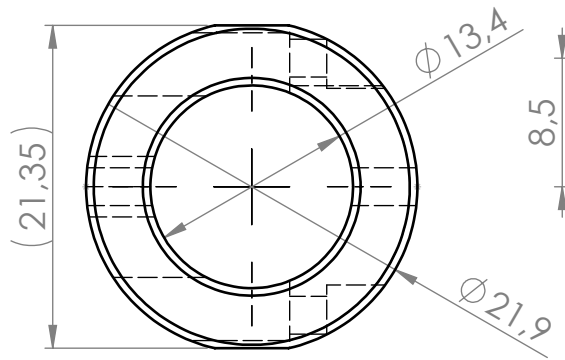

(CELKEM 5x M3)

www.r-vm.cz	Model/Designed		Kreslil/Drawn by VESELÝ		Zákazník/Customer		Materiál/Material Al 7075		Ks/Pcs 30x 250x 1000x
	Měřítko/Scale 2:1	Promítání/Projekce ⊘	Datum/Date		Projekt/Project		Teplotní úprava/Heat treatment		
	Přesnost/Precision ISO 2768 mK	Tolerování/Tolerance ISO 8015	Hmotnost/Weight [g]		Povrchová úprava/Surface treatment ČERNÝ ELOX		Barva/Color -		
Název/Title					Číslo výkresu/Drawing No. 17.4-015F				
									1/1